

PRELIMINARY - BiSS ABSOLUTE SINGLE TURN ENCODERS, CHM9 RANGE

Especially designed for heavy-duty (steel, paper, wood – mills, cranes ...) Compact and robust conception. Excellent resistance to shocks/vibrations and to extreme axial/radial loads



Also available in SSI or parallel output and fieldbus: CanOpen, DeviceNet, Profibus



CHM9_11 connection S6 or S8 (radial or axial M23)

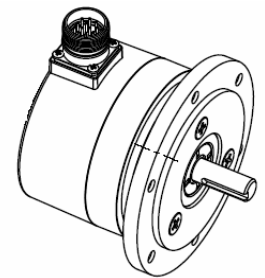
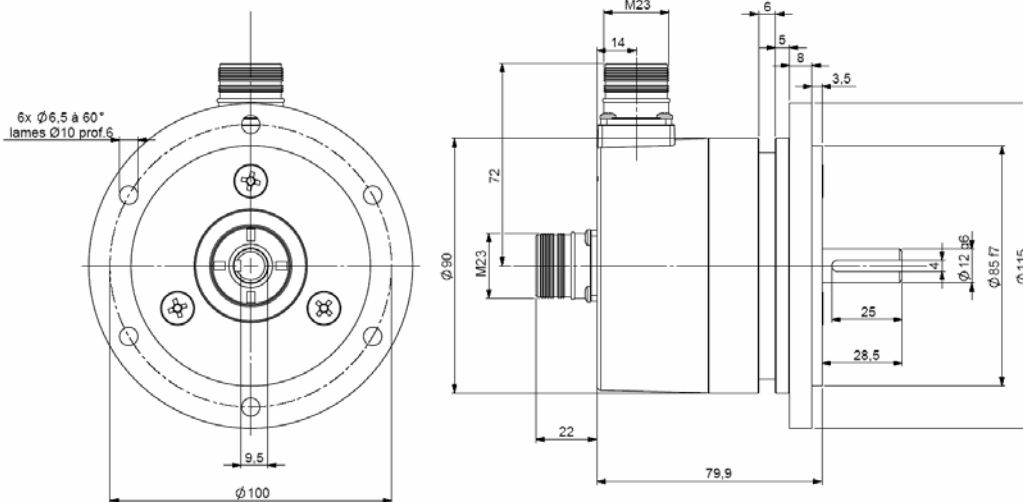

CHM9_12 connection S5R (radial cable)

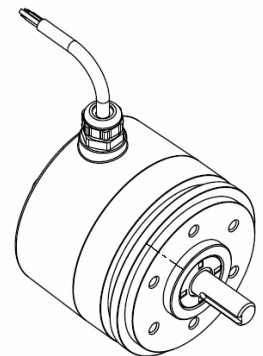
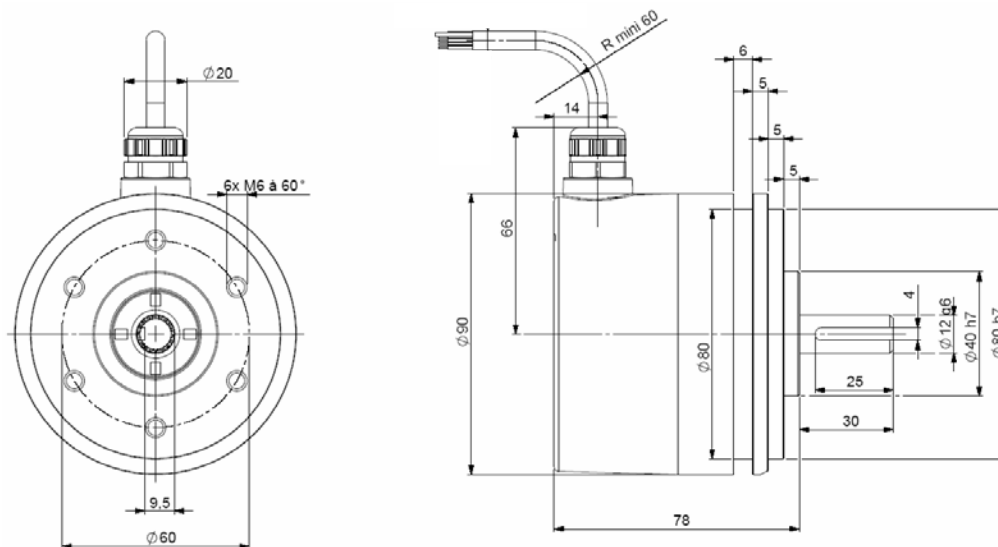

Material	Cover : zinc alloy
Stainless steel option	Body : aluminium
Shaft material	Stainless steel
Bearings	6001 serie
Maximal loads	Axial : 100 N
	Radial : 200 N
Shaft inertia	$\leq 15 \cdot 10^{-6} \text{ kg.m}^2$
Torque	$\leq 10 \cdot 10^{-3} \text{ N.m}$
Permissible max. speed	9 000 min ⁻¹
Continuous max. speed	6 000 min ⁻¹
Shaft seal	Viton double lips
Shocks (EN60068-2-27)	$\leq 500 \text{ m.s}^{-2}$ (during 6ms)

Vibrations (EN60068-2-6)	$\leq 200 \text{ m.s}^{-2}$ (10 ... 1 000 Hz)	
EMC	EN 6100-6-4, EN 61000-6-2	
Isolation	1 000 Veff	
Encoder weight (approx)	1,100kg zinc alloy cover, alu body	
	2,400kg zinc alloy cover, stainless steel body 2,600kg stainless steel cover and body	
Operating temperature	- 20 ... + 90 °C (encoder T°)	
Storage temperature	- 40... + 100°C	
Protection(EN 60529)	IP 67 (cable), IP 66 (connector)	
Theoretical mechanical lifetime 10 ⁹ turns (F _{axial} / F _{radial})		
20 N / 30 N	50 N / 100 N	100 N / 200 N
360	18	2,2

PRELIMINARY - BISS ABSOLUTE SINGLE TURN ENCODERS, CHM9 RANGE



- Bi-directional
- Synchronous-serial communication
- Short cycle times
- Up to 8 slaves with one master
- Multicycle data transmission

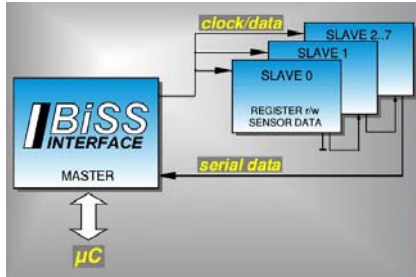

The BiSS Interface master-slave concept supports up to 8 data sources in one or more devices

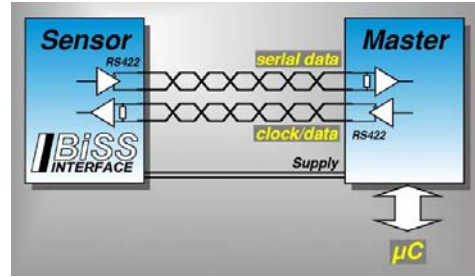

BiSS Interface wiring with unidirectional lines (one sensor with several slave levels, for example)

CHM9 BiSS encoder is slave 0. Consult us in the case of other slave number

Power supply Vcc	5 to 30Vdc (polarity protected)	Introduction	<1s
Consumption without load	Max 100mA	Inputs	DIRECTION and RESET
Outputs	Level high ≥ 2,5V (for I=20mA) Load high ≤ -20mA BiSS: RS-422	Level low ≤ 0,5Vdc (for I=20mA) Load low ≤ 20mA	
For more information: www.biss-interface.com			

BISS STANDARD CONNECTION

Type	Vcc	0V	Clk+	Data+	RAZ	Data-	Clk-	DIRECTION
S6	1	2	3	4	5	6	7	9
S5	BN/GN Brown/Green	WH/GN White/Green	GN Green	GY Grey	BU Blue	PK Pink	BN Brown	WH White
S8	8	1	3	2	6	10	11	5

DIRECTION input

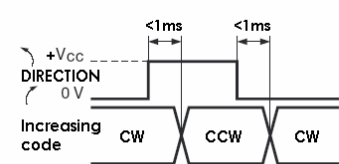

Level "0"	min 0 V	max 0,3x(+Vcc)	Increasing CW
Level "1"	0,7x(+Vcc)	+Vcc	CCW
I direction	< 5mA		

RAZ / RAX input

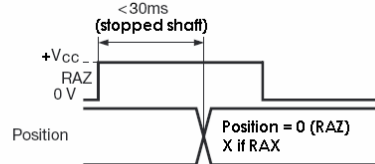

Level "0"	min 0 V	max 0,3x(+Vcc)
Level "1"	0,7x(+Vcc)	+Vcc
I raz/rax	< 5mA	

Nota: Do not connect other pinouts, connect DIRECTION and RAZ to a potential (RAZ at 0V if not used)

ORDERING REFERENCE (Contact the factory for special versions, ex: special flanges, connections, electronics...)

	Shaft Ø	Supply	Output stage	Code	Resolution	Connection	Orientation
CHM9	12 : 12mm	P : 5 to 30Vdc	CB : BiSS electronic	B: Binary	Max: 20 bits, power of 2 13: 13 bits to 19: 19 bits 20 bits: consult us	S6 : M23 12pins CW S8 : M23 12pins CCW	R : radial
				G: Gray		S5 : cable gland output	Example : R020 : radial cable of 2m
CHM9 _	12 //	P	CB	G //	13 //	S5	R050

Monitoring function available in option :

- of the code coherence
- of the LED internal regulated current loop
- of temperature range with 2 limits

Input / output available in option:

- ERROR output for monitoring functions
- Sine & Cosine outputs without index, 2048ppr (option: 4096 ppr)
- A & B incremental outputs without index, 2048ppr (option: 4096 ppr)

Consult us