

INCREMENTAL ENCODERS, GHT9 RANGE

- Especially designed for heavy-duty applications: steel, paper mills, food industry, compact and robust encoder, it's connection is done with industrial connector or shielded cable
- Hollow shaft: 10, 11 or 12mm
- Digital incremental signals, option analogue output signals (Tachoencoders , optotachos)
- Self-monitoring MaxControl (optional) : detection of shocks, vibrations, temperatures, etc.
- Double/triple mounting in combinations of incremental, absolute, analog signals, overspeed switch

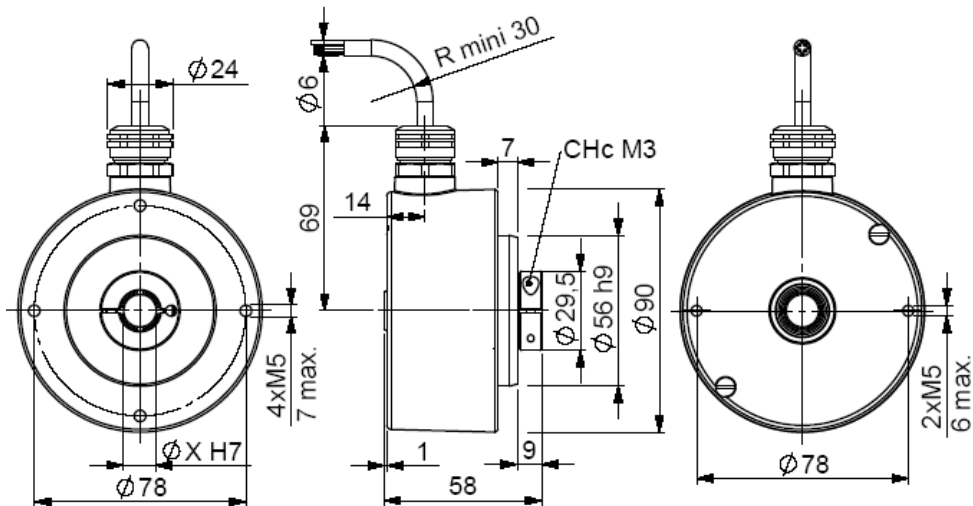

GHT9 connection G3R (radial cable)



GHT9_12 connection G6R (radial M23), with MEFLEX 9445/004 monted on the body

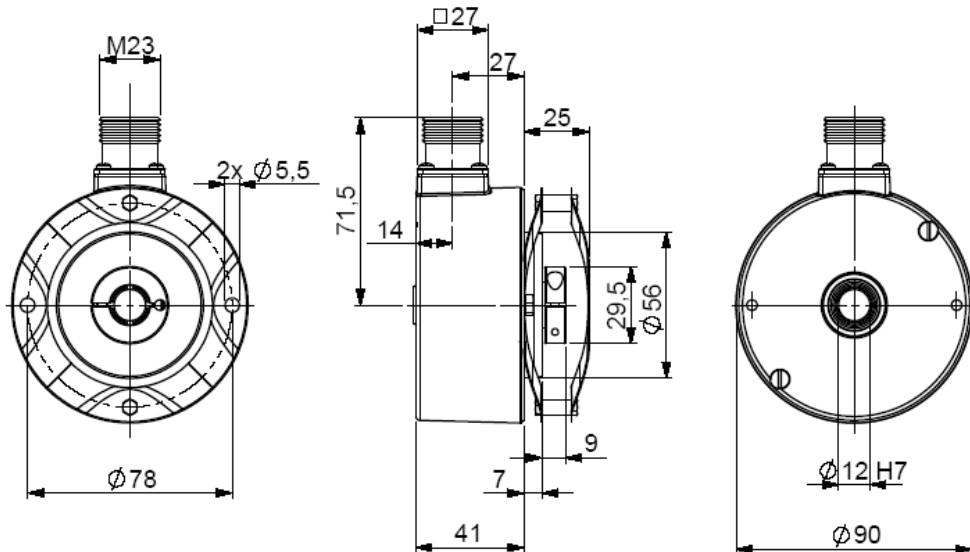

Material	Cover : zinc alloy
Stainless steel option	Body: aluminium
Shaft	Stainless steel
Bearings	61902 serie
Maximal loads	Axial : 50 N
	Radial : 100 N
Shaft inertia moment	$\leq 5,5 \cdot 10^{-6}$ kg.m ²
Torque	$\leq 15 \cdot 10^{-3}$ N.m
Permissible max. speed	9 000 min ⁻¹
Continuous max. speed	6 000 min ⁻¹
Shaft seal	Nitril
Shock (EN60068-2-27)	≤ 500 m.s ⁻² (during 6 ms)

Vibration (EN60068-2-6)	≤ 200 m.s ⁻² (10 ... 1 000 Hz)
EMC	EN 50081-1, EN 61000-6-2
Isolation	1 000 V
Weight	0,85 kg zinc alloy cover, alu body
	1,0 kg zinc alloy cover, stainless steel body
	1,2 kg stainless steel cover and body
Operating temperature	- 20 ... + 80 °C (encoder T°)
Storage temperature	- 40 ... + 80 °C
Protection(EN 60529)	IP 65
Theoretical mechanical lifetime 10 ⁹ turns (F _{axial} / F _{radial})	
25 N / 50 N	50 N / 100 N
87	11

INCREMENTAL ENCODERS, GHT9 RANGE

OUTPUT ELECTRONIC / SUPPLY

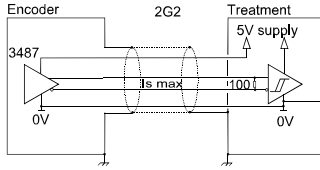

2G2 electronic (100kHz)
Supply : 5Vdc ± 10%
Cons. without load : 100mA max
Current per channel : 40mA max
0 max (Is=20mA) : $V_{ol} = 0,5Vdc$
1 min (Is=20mA) : $V_{oh} = 2,5Vdc$

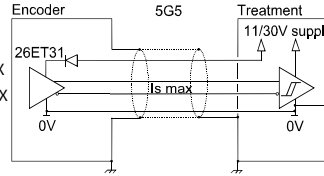

5G5 electronic (100kHz)
Supply : 11 to 30Vdc
Cons. without load : 75mA max
Current per channel : 40mA max
0 max (Is=20mA) : $V_{ol} = 0,5Vdc$
1 min (Is=20mA) : $V_{oh} = Vcc-3Vdc$

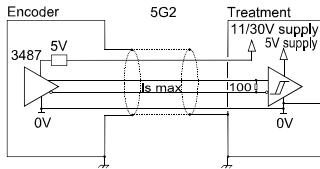

5G2 electronic (100kHz)
Supply : 11 to 30Vdc
Cons. without load : 75mA max
Current per channel : 40mA max
0 max (Is=20mA) : $V_{ol} = 0,5Vdc$
1 min (Is=20mA) : $V_{oh} = 2,5Vdc$

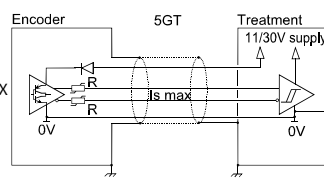

5GT electronic, optional (100kHz)
Supply : 11 to 30Vdc
Cons. without load : 75mA max
Current per channel : 40mA max
0 max (Is=20mA) : $V_{ol} = 0,5Vdc$
1 min (Is=20mA) : $V_{oh} = Vcc-2,5Vdc$

Electronics 5GT is designed for long and high capacity cables (contact our factory)

Available in option :

- 3G3 electronic, supply between 15 and 30Vdc, push-pull output regulated 12Vdc
- 5GH electronic permits to drive different inputs (plc + display for example)

Protection against short circuits the electronics: 5G5, 5GT, 3G3

Protection against inversion of polarity for all the electronics except 2G2

Option "Max control" : the encoder gives on real time its physical environment parameters: shocks and vibrations, too high or too low temperature, too low or too high supply, quality of the output signals : upon request..



STANDARD CONNECTION

		-	+	A	B	0	A/	B/	0/	Ground
G6	12 pins CW	1	2	3	4	5	6	7	8	connector body
G8	12 pins CCW	10 + 11	2 + 12	8	5	3	1	6	4	connector body
G3	Cable PVC 8 wires 8230/020	WH white	BN brown	GN green	YE yellow	GY grey	PK pink	BU bleu	RD red	general shielding
GP	Cable PUR 12 wires 8230/050	WH white + WH/GN white /green	BU blue + BN/GN brown/green	GY grey	BN brown	RD red	PK pink	GN green	BK black	general shielding

ORDERING REFERENCE (Contact the factory for special versions ex: overspeed switch, electronics, special flanges, connections ...)

	Shaft Ø	Available electronic		Output signal	Resolution	Connection	Connection orientation		
GHT9 Cover : zinc Body: alu	10: 10mm 11: 11mm 12: 12mm	2G2, 5G2, 5G5, 5GT, 5GH, 3G3		9 : A,A/,B,B/,0,0/ (0, A&B gated)	10 000 max	G6 : M23 12 pins CW G5 : M23 12 pins CCW G8 : M23 12 pins CCW	R : radial		
		Supply	Output stages						
		GBT9 Cover : zinc Body: stainless steel				2 : 5Vdc 5 : 11 to 30Vdc 3 : 15 to 30Vdc	G2 : driver 5Vdc RS422 G3 : driver 12Vdc G5 : push-pull GT : push-pull 11-30Vdc transistorised GH : push-pull 11-30Vdc 150 mA	A : A,A/,B,B/,0,0/ (0, A gated)	
GXT9 Cover and body: stainless steel				N : A,A/,B,B/,0,0/ (0 ungated)					
Ex: GHT9	12	//	5	G5	9	//	5 000//	GP	R020

Available resolutions : 1 2 3 4 5 6 8 9 10 12 14 16 20 24 25 30 32 40 45 50 60 62 63 64 70 72 80 84 88 89 90 96 100 120 122 125 127 128 130 150 157 180 200 205 240 250 256 300 305 314 330 350 360 400 425 450 500 512 540 550 565 580 600 628 630 632 650 700 720 750 754 800 810 880 900 990 1000 1024 1080 1131 1152 1200 1250 1290 1440 1500 1600 1620 1800 2000 2048 2400 2500 2640 3000 3600 4000 4096 5000 7200 7335 9000 10000

Made in FRANCE