

## PROGRAMMABLE INCREMENTAL ENCODERS, DHO5 RANGE, DIGISINE™

The programmable encoder : **DIGISINE™**, unique combination of performance and flexibility

- Easy programming without any specific soft- nor hard-ware
- High resolutions available : up to 80 000 cpt
- Through hollow shaft version Ø14mm, with reduction hubs in aluminium of 6, 8, 10 and 12 mm
- Easy mounting for the hollow shafts thanks to DAC (Anti-Coupling Device)
- Robustness and excellent resistance to shocks / vibrations
- High protection level: standard IP65
- Universal electronic circuits from 5 to 30 Vdc
- High performances in temperature -30°C to +70°C (option -40°C)
- High performances in frequency of output signals : 300 kHz



### DHO5\_14 connection G6R (radial M23), DAC 9445/015\* mounted on body

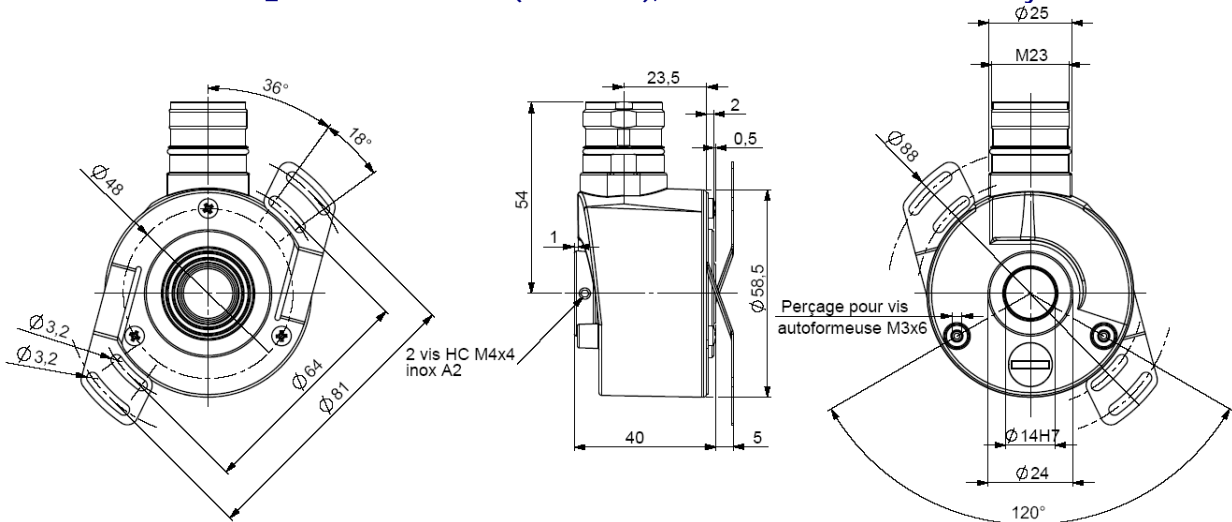

### DHO5\_14 connection G3R (radial cable), DAC 9445/015\* mounted on cover

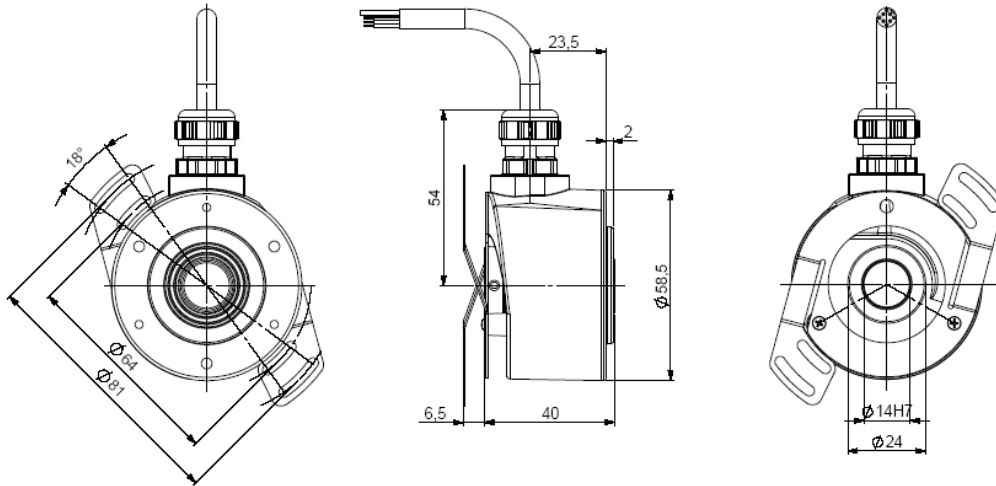

\* Accessory to be ordered separately

Material	Cover : zinc alloy	Shocks (EN60068-2-27)	≤ 500 m.s <sup>-2</sup> (during 6 ms)
	Body : aluminium	Vibrations (EN60068-2-6)	≤ 100 m.s <sup>-2</sup> (55 ... 2 000 Hz)
	Shaft : stainless steel	EMC	EN 50081-1, EN 61000-6-2
Bearings	6 803 serie	Isolation	1 000 V eff
Maximal loads	Axial : 20 N	Encoder weight (approx.)	0,300 kg
	Radial : 50 N	Operating temperature	- 30 ... + 70°C (encoder T°)
Shaft inertia	≤ 2,2.10 <sup>-6</sup> kg.m <sup>2</sup>	Storage temperature	- 40 ... + 80°C
Torque	≤ 6.10 <sup>-3</sup> N.m	Protection(EN 60529)	IP 65
Permissible max. speed	9 000 min <sup>-1</sup>	Torque (ring pressure screw)	nominal: 1.5 N.m, break: 2.0 N.m
Continuous max. speed	6 000 min <sup>-1</sup>	Theoretical mechanical lifetime 10 <sup>9</sup> turns (F <sub>axial</sub> / F <sub>radial</sub> )	
Shaft seal	Viton	10N / 25N : 230	20N / 50N : 29

## PROGRAMMABLE INCREMENTAL ENCODERS, DHO5 RANGE, DIGISINE™

### DIGITAL OUTPUT SIGNALS (SQUARE WAVE)

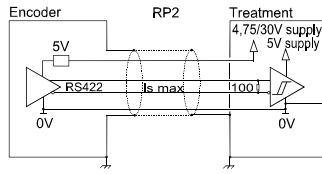

#### RP2 electronic (300kHz)

Supply : 4,75 to 30Vdc  
Cons. without load : 75mA max  
Current per channel: 40mA max  
0 max (Is=20mA) :  $V_{ol} = 0,5Vdc$   
1 min (Is=20mA) :  $V_{oh} = 4Vdc$

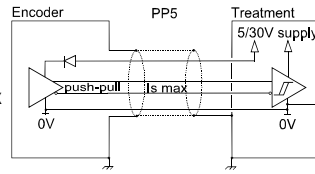

#### PP5 electronic (300kHz)

Supply: 5 to 30Vdc  
Cons. without load : 75mA max  
Current per channel: 40mA max  
0 max (Is=20mA) :  $V_{ol} = 0,5Vdc$   
1 min (Is=20mA) :  $V_{oh} = V_{cc}-2,5Vdc$

Protection against short circuits and against reverse polarity for all the electronics

### STANDARD CONNECTION

		-	+	A	B	0	A/	B/	0/	Ground
G6	M23 - 12 pins CW	1	2	3	4	5	6	7	8	Connector body
G8	M23 - 12 pins CCW	10 + 11	2 + 12	8	5	3	1	6	4	Connector body
G3	PVC cable 8 wires 8230/020	WH white	BN brown	GN green	YE yellow	GY grey	PK pink	BU blue	RD red	General shielding
GP	PUR cable 12 wires 8230/050	WH white + WH/GN white / green	BU blue + BN/GN brown / green	GY grey	BN brown	RD red	PK pink	GN green	BK black	General shielding

### ORDERING REFERENCE (Contact the factory for special versions, ex: special electronics, flanges, connections...)

DHO5	Shaft Ø	Digital signals (Square wave)				Resolution	Connection	Connection orientation
		Electronic : PP5, RP2		Output signals	Resolution			
		Supply	Output stage					
14 : 14mm reduction hubs available up to 6mm	R : 4.75 to 30Vdc P : 5 to 30Vdc	P2 : driver 5Vdc RS422 P5 : push-pull	9 : A,A/B,B/0,0/ (0 gated A & B)	5 000 max basic resolution	G6 : M23 12 pins CW G5 : M23 12 pins CW G8 : M23 12 pins CCW G2 : DIN 5 pins GD : DIN 8 pins	R : radial		
							G3 : PVC cable 8 wires GP : PUR cable 12 wires	Example : R020 : radial cable 2m
Ex: DHO5 _	14 //	P	P5	9 //	5 000 //	GP	R020	

### AVAILABLE INTERPOLATED RESOLUTIONS

Easy multiplication of the basis resolution of the disk : 1, 2, 3, 4, 5, 8, 10, 12 and 16 times per dip-switch without specific software nor hardware



Interpolation factor	Basis resolution										
	250	256	360	500	1 024	2 500	3 000	3 600	4 000	4 096	5 000
X1	250	256	360	500	1 024	2 500	3 000	3 600	4 000	4 096	5 000
X2	500	512	720	1 000	2 048	5 000	6 000	7 200	8 000	8 192	10 000
X3	750	768	1 080	1 500	3 072	7 500	9 000	10 800	12 000	12 288	15 000
X4	1 000	1 024	1 440	2 000	4 096	10 000	12 000	14 400	16 000	16 384	20 000
X5	1 250	1 280	1 800	2 500	5 120	12 500	15 000	18 000	20 000	20 480	25 000
X8	2 000	2 048	2 880	4 000	8 192	20 000	24 000	28 800	32 000	32 768	40 000
X10	2 500	2 560	3 600	5 000	10 240	25 000	30 000	36 000	40 000	40 960	50 000
X12	3 000	3 072	4 320	6 000	12 288	30 000	36 000	43 200	48 000	49 152	60 000
X16	4 000	4 096	5 760	8 000	16 384	40 000	48 000	57 600	64 000	65 536	80 000

switchs position	
factor	CODE SWITCH
	1 2 3 4
x 1	ON <input type="checkbox"/> <input type="checkbox"/> <input type="checkbox"/> <input type="checkbox"/>
x 2	ON <input type="checkbox"/> <input type="checkbox"/> <input type="checkbox"/> <input type="checkbox"/>
x 3	ON <input type="checkbox"/> <input type="checkbox"/> <input type="checkbox"/> <input type="checkbox"/>
x 4	ON <input type="checkbox"/> <input type="checkbox"/> <input type="checkbox"/> <input type="checkbox"/>
x 5	ON <input type="checkbox"/> <input type="checkbox"/> <input type="checkbox"/> <input type="checkbox"/>
x 8	ON <input type="checkbox"/> <input type="checkbox"/> <input type="checkbox"/> <input type="checkbox"/>
x 10	ON <input type="checkbox"/> <input type="checkbox"/> <input type="checkbox"/> <input type="checkbox"/>
x 12	ON <input type="checkbox"/> <input type="checkbox"/> <input type="checkbox"/> <input type="checkbox"/>
x 16	ON <input type="checkbox"/> <input type="checkbox"/> <input type="checkbox"/> <input type="checkbox"/>

Made in France