

POSI+ CANOPEN USER MANUAL



ABSOLUTE ROTARY ENCODER WITH CAN-BUS INTERFACE POSI+ RANGE USER MANUAL

POSI+ CANOPEN USER MANUAL**CONTENTS**

1. Introduction	3
1.1 Absolute rotary encoder	3
1.2 CANopen technology	3
1.3 CAN Communication Reference Model	5
1.4 Definitions	6
1.5 Troubleshooting	7
2. Device Configuration	8
2.1. CANopen Data Transmission	8
Data Transmission - COB-ID	
2.2. Service data communication	9
Request for parameter – Parameter to the encoder - Index / Sub-index - SDO examples: Request of a value by the master from the slave Writing of a value by the master into the slave	
2.3 Process data communication	11
Synchronous- Cyclical (asynchronous) - Response to an RTR message -Transmission of the current position	
3. Operational mode	12
Init - Pre-operational mode - Operational mode - Stopped mode - Reset of the absolute rotary encoder	
4.Communication objects 1000h to 1FFFh (DS 301)	14
Object 1010h: Store parameters Object 1011h: Restore Default parameters Object 1800h: 1st Transmit PDO communication Parameter Transmission mode COB-ID Structure Inhibit Time (Sub-index 3) Event Timer (Sub-index 5) Object 1801h: 2nd Transmit PDO communication Parameter	
5. Manufacturer-specific Objects 2000h to 5FFFh	20
Object 2002h: Speed Object 2005h: PDO type Object 2100h: Transmission Rate Object 2101h: Node Number	
6. Encoder-specific objects 6000h to 9FFFh (DS 406)	22
Object 6000h: Operating Parameters Object 6001h: Measuring Units per revolution Object 6002h: Total measuring range in measuring units Object 6003h: Preset Value Object 6004h: Position Value Object 6200h: Cyclic Timer Object 6500h: Operating Status Object 6501h: Singleturn Resolution (Rotary) Object 6502h: Number of Distinguishable Revolutions Object 6503h: Alarms Object 6504h: Supported Alarms Object 6505h: Warnings Object 6506h: Supported Warnings Object 6507h: Profile and Software Version Object 650Ah: Module identification Object 650Bh: Serial Number	
Appendix: Compatibility with with the old encoders SHM5/SHU9/CHU9/MHM5	31

POSI+ CANOPEN USER MANUAL

1. Introduction

This manual describes the implementing and configuration of an absolute rotary encoder with CANopen interface. The device fulfills the requirements of a CANopen device regarding the device specification DS406 of the CANopen user group.

1.1 Absolute rotary encoder

The basic principle of an absolute rotary encoder is the optical sampling of a transparent code disc which is fixed with the driving shaft.

The absolute rotary encoder has a maximum resolution of 8192 steps per revolution (13 Bit). The Multi-Turn version can detect up to 65536 revolutions (16Bit). Therefore the largest resulting resolution is 29 Bit = $2^{29} = 536.870.912$ steps. The standard Single-Turn version has 13 Bit, the standard Multi-Turn version 29 Bit.

Open functions. The following modes can be programmed and enabled or disabled:

- RTR Message (Polled mode)
- Cyclic Mode
- Sync Mode

The protocol supports the programming of the following additional functions:

- Code sequence (Complement)
- Resolution per revolution
- Total revolutions
- Preset value
- Two limit switches
- Baudrate
- Node number

The general use of absolute rotary encoders with CAN-Bus interface using the CAN Open protocol is guaranteed.

1.2 CANopen technology

CAN stands for Controller Area Network and was developed by the company Bosch for applications within the automobile area. In the meantime CAN has become increasingly used for industrial applications. CAN is a multi-masterable system, i.e. all users can access the bus at any time as long as it is free. CAN doesn't operate with addresses but with message identifiers. Access to the bus is performed according to the CSMA/CA principle (carrier sense multiple access with collision avoidance), i.e. each user listens if the bus is free, and if so, is allowed to send messages. If two users attempt to access the bus simultaneously, the one with the highest priority (lowest identifier) receives the permission to send. Users with lower priority interrupt their data transfer and will access the bus when it is free again. Messages can be received by every participant. Controlled by an acceptance filter the participant accepts only messages that are intended for it.

POSI+ CANOPEN USER MANUAL

CANopen

Transmission Technology:	Two-core cable
Baud rates:	10 kBaud up to 1 MBaud
Participants:	maximum 127
Cable Length:	30 m for 1 MBaud 1000 m for 20 kBaud

The data communication is done via message telegrams. In general, telegrams can be split in a COB-Identifier and up to 8 following bytes. The COB-Identifier, which determines the priority of the message, is made from the function code and the node number.

The node number is uniquely assigned to each user. The function code varies according to the type of message transmitted:

- Administrative messages (LMT, NMT)
- Service data objects (SDOs)
- Process data Objects (PDOs)
- pre-defined messages (synchronization, emergency messages)

PDOs (Process Data Objects) are needed for real time data exchange. Since this messages possess a high priority, the function code and therefore the identifier are low. SDOs (service data objects) are necessary for the bus node configuration (e.g. transfer of device parameters). Because these message telegrams are transferred acyclicly (usually only while powering up the network), the priority is low.

BEI IDEACOD rotary encoders with CANopen interface support all CANopen functions. The following operating modes can be programmed:

- Response to a RTR message (Polled mode):
The position value is only given upon request
- Cyclic Mode:
The position value is written cyclically (interval adjustable) to the bus
- Sync mode:
After receiving a sync message by the host, the encoder answers with the current process value. If a node is not required to answer after each sync message, a parameter sync counter can be programmed to skip a certain number of sync messages before answering again

Further functions (direction of rotation, resolution, etc..) can be parameterized. BEI IDEACOD rotary encoders correspond with the class 2 profile for encoder (DS 301 V4.0.2, DS 406 V3.1), whereby the characteristics of rotary encoders with CANopen interface are defined. For configuration and parameterization various software tools are available from different providers. With the help of the provided EDS file (electronic datasheet) simple line-up and programming are possible.

POSI+ CANOPEN USER MANUAL

1.3 CAN Communication Reference Model

The communication concept can be described similar to the ISO-OSI Reference Model:

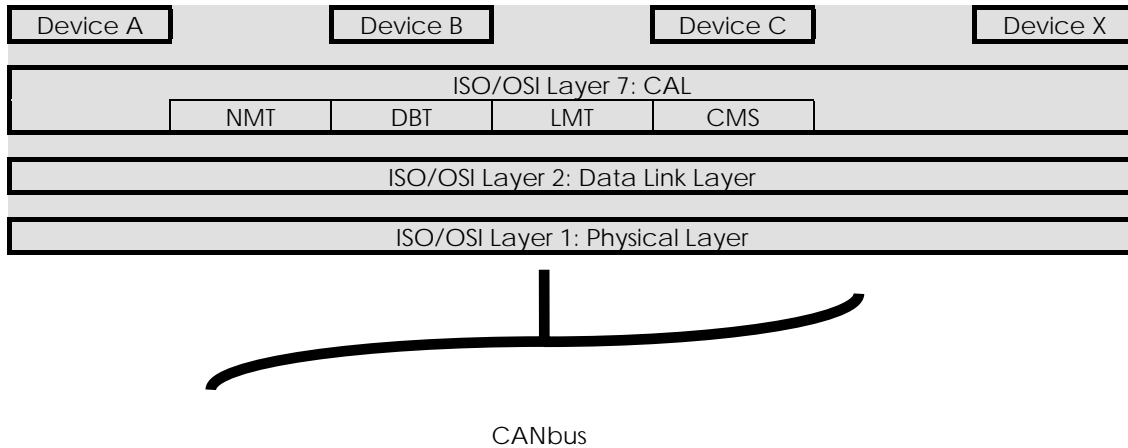

The communication model* supports synchronous and asynchronous messages. With respect to the functionality four different message objects are provided:

- Administrational Messages (LMT, NMT)
- Service Data Messages (SDO)
- Process Data Messages (PDO)
- Pre-defined Messages (Synchronisation and Emergency Messages)

Further information is available at:

CAN in Automation (CiA) International Users and Manufacturers Group e.V.
Am Weichselgarten 26
D-91058 Erlangen

- (*) Reference: CAN Application Layer for Industrial Applications
CiA Draft Standard 201 ... 207, Version 1.1
CAL-based Communication Profile for Industrial Systems
CiA Draft Standard 301

POSI+ CANOPEN USER MANUAL

1.4 Definitions

CAN	Controller Area Network
CAL	CAN Application Layer
CMS	CAN Message Specification. One of the service elements of the application layer in the CAN Reference Model.
COB	Communication Object. (CAN message) A unit of transportation in a CAN Network. Data must be sent across a Network inside a COB.
COB-ID	COB-Identfier. Identifies a COB uniquely in a Network. The identifier determines the priority of that COB.
LMT	Layer Management. One of the service elements of the application layer in the CAN Reference Model. It serves to configure parameters of each layer in the CAN Reference Model.
NMT	Network Management. One of the service elements of the application layer in the CAN Reference Model. It performs initialisation, configuration and error handling in a CAN network.
SDO	Service Data Object. A data object with low priority to configure a CAN node.
PDO	Process Data Object. A data object with high priority to transmit data in synchronous and asynchronous modes.

Additionally, following abbreviations are used in the manual:

APV	Absolute Position Value
CW	Clockwise. Turning direction as seen on shaft.
CCW	Counterclockwise. Turning direction as seen on shaft.
FC	Function code. It determines the kind of message, which is sent across the CAN network.
NN	Node number. It determines uniquely the CAN device.
PV	Preset value
PCV	Process value

POSI+ CANOPEN USER MANUAL

1.5 Troubleshooting

Malfunction of the position value during transmission

Problem:

During the transmission of the position value occasional malfunctions occurs.

Possible solution:

Check, if the last bus node has switched on the terminal resistor.

Too much ERROR-Frames

Problem:

The bus load is too high in case of too much error frames.

Possible solution:

Check if all bus node has the same baudrate. If one node has another baudrate error frames are produced automatically.

Installation hints

Both the cable shielding and the metal housings of encoders and subsequent electronics have a shielding function. The housing must have the same potential and be connected to the main signal ground over the machine chassis or by means of a separate potential compensating line. Potential compensating lines should have a minimum cross section of 6 mm².

Do not lay signal cable in the direct vicinity of interference sources (air clearance > 100 mm (4 in.).

A minimum spacing of 200 mm (8 in.) to inductors is usually required, for example in switch-mode power supplies.

Configure the signal lines for minimum length and avoid the use of intermediate terminals.

In metal cable ducts, sufficient decoupling of signal lines from interference signal transmitting cable can usually be achieved with a grounded partition.

POSI+ CANOPEN USER MANUAL

2. Device Configuration

2.1. CANopen Data Transmission

Data Transmission

Data is transmitted in a CANopen network in the form of messages. These messages basically consist of a COB-ID and 8 data bytes.

COB-ID The 11-bit COB-ID is made up as follows:

10	9	8	7	6	5	4	3	2	1	0			
Function code				Node number									
X	X	X	X	X	X	X	X	X	X	X		X free, to be selected	

The COB-ID only determines the message object. It consists of a function code, which identifies the message class and the node number, which is the absolute encoder address. The node number is fixed using the two rotary switches located on the base.

The following function codes are available (rx and tx as viewed by the master):

Object	Function code (binary)	COB-ID result	Hex.	Priority class*
NMT	0000	0		0
SYNC	0001	128	80	0
Emergency	0010	129-255	81-FF	0,1
PDO (tx)	0011	385-511	181-1FF	1,2
PDO (rx)	0100	513-639	201-27F	2
PDO (tx)	0101	641-767	281-2FF	2,3
PDO (rx)	0110	769-895	301-37F	3,4
SDO (tx)	1011	1409-1535	581-5FF	6
SDO (rx)	1100	1537-1663	601-67F	6,7

* Priority: 0= maximum priority, 7=minimum priority

POSI+ CANOPEN USER MANUAL

2.2. Service data communication

The service data objects correspond to the standards of the CiA. It is possible to access an object via index and subindex. The data can be requested or where applicable written into the object.

COB-ID	Command	Index		Sub Index	Service Data (Parameters)			
11 bit	Byte 0	Byte 1 (LSB)	Byte 2 (MSB)	Byte 3	Byte 4 (LSB)	Byte 5	Byte 6	Byte 7 (MSB)

COB-ID

An SDO-**COB ID** is composed as follows:

Master -> Encoder : 600h + Node ID

Encoder -> Master : 580h + Node ID

Request for parameter

Command	Function	Description
40h	Master -> Encoder	Request for parameter
43h	Encoder -> Master	Response 4 bytes (unsigned 32)
4Bh	Encoder -> Master	Response 2 bytes (unsigned 16)
4Fh	Encoder -> Master	Response 1 byte (unsigned 8)
80h	Encoder -> Master	Error

Parameter to the encoder

Command	Function	Description
23h	Master -> Encoder	Write 4 bytes (unsigned 32)
2Bh	Master -> Encoder	Write 2 bytes (unsigned 16)
2Fh	Master -> Encoder	Write 1 byte (unsigned 8)
60h	Encoder -> Master	Parameter received
80h	Encoder -> Master	Error

POSI+ CANOPEN USER MANUAL

Index / Sub-index

Data is transmitted solely using objects referenced by index. The objects are simple or composed type. In this case, the index associated to the composed object will be subdivided into several sub-index. The number of sub-index is specified into subindex 0, it can be from 1 to 254. Each object is described into a object dictionary.

The organization of a standard object dictionary is shown in the following table:

Index (hex)	Object
0000	Not used
0001-001F	Static data types
0020-003F	Complex data types
0040-005F	Manufacturer specific data types
0060-0FFF	Reserved
1000-1FFF	Communication area (see Communication profile objects 1000h to 1FFFh (DS301))
2000-5FFF	Manufacturer specific area (see Manufacturer-specific Zone Objects 2000h to 5FFFh)
6000-9FFF	Device profile specific area (see Hardware Profile objects 6000h to 9FFFh (DS406))
A000-FFFF	Reserved

SDO examples

Request of a value by the master from the slave

A frequent request will be a request for position Object 6004h

COB-ID	Command	Index		Sub Index	Service Data (Parameters)			
600h+node ID	40h	04h	60h	00h	X	X	X	X

Response by the slave to the request for a value

The position is 4 bytes long, the precise values can be found under object 6004h.

COB-ID	Command	Index		Sub Index	Service Data (Parameters)			
580h+node ID	43h	04h	60h	00h	Pos0	Pos1	Pos2	Pos3

Writing of a value by the master into the slave

Position setting can be performed with preset. Object 6003h

COB-ID	Command	Index		Sub Index	Service Data (Parameters)			
600h+node ID	22h	03h	60h	00h	Pre0	Pre1	Pre2	Pre3

Slave's response to the writing of a value

COB-ID	Command	Index		Sub Index	Service Data (Parameters)			
580h+node ID	60h	03h	60h	00h	0	0	0	0

POSI+ CANOPEN USER MANUAL

2.3. Process data communication

Process data objects are used for real time data exchange for process data :position. PDOs can be transmitted synchronously or cyclically (asynchronously). The encoder supports the PDO1 and the PDO2. Both PDOs supply the current position of the encoder and are defined in the objects 1800h,1801h, 1A00h, 1A01.

Synchronous

In order to transmit the process data synchronously, a value between 1 and F0h (=240) must be written into the object 1800h / 1801h Subindex 2. If the value is 3, the PDO is transmitted on every third sync telegram (if the value 1 is entered, transmission takes place on every sync telegram)
In synchronous operation, the PDO is requested by the master via the Sync telegram (COB-ID = 80h).

Cyclical (asynchronous)

If you wish the PDOs to be transmitted cyclically, the value FEh must be written into the object 1800h / 1801h Subindex 2. In addition, the cycle time in milliseconds must be entered in the same object subindex 5. The entered time is rounded off to 1 ms. If the value is stored for 0 ms, the PDOs are not transmitted. The function is switched off.

Response to an RTR message

by means of the remote frame = recessive RTR bit, precisely the message with the transferred identifier will be requested

Transmission of the current position

The process value is sent on the CAN network with the following message:

COB-ID	Process value			
11 bits	Byte 0	Byte 1	Byte 2	Byte 3
	2^7 to 2^0	2^{15} to 2^8	2^{23} to 2^{16}	2^{31} to 2^{24}

The COB-ID contains the node number and the corresponding PDO(tx). By default, the sended process value use the COB-ID 0180h+Node-ID and, in response to the SYNC message, use the COB-ID 0280h+Node ID.

The PDO COB-ID are defined in the object 1800h/1801h subindex 1.

POSI+ CANOPEN USER MANUAL

3. Operational mode

Principle The absolute rotary encoder accesses the CAN network less one second after powerup in pre-operational mode.

Init

Following initialization, the encoder logs on to the CAN bus with a BootUp message. The encoder then goes automatically to the pre-operational mode status. The COB ID of the BootUp message is made up of 700h and the node ID.

COB-ID	Byte 0
700h+Node ID	00

Pre-operational mode

In the pre-operational mode, SDOs can be read and written.

Operational mode

In the operational mode, the encoder transmits the requested PDOs. In addition, SDOs can be read and written.

Stopped mode

In the stopped mode, only NMT communication is possible. No SDO parameters can be read or set.

Reset of the absolute rotary encoder

If a node is not operating correctly, it is advisable to carry out a Reset.

COB-ID	Command (Byte 0)	Node Number (Byte 1)	Description
00h	81h	00h	NMT Reset Remote Node, all Node
00h	81h	01h..7Fh	NMT Reset Remote Node node number

After Reset, the absolute rotary encoder accesses the bus in pre-operational mode.

POSI+ CANOPEN USER MANUAL

Mode: Preoperational

To set a node to pre-operational mode, the master must send the following message:

COB-ID	Command (Byte 0)	Node Number (Byte 1)	Description
00h	80h	00h	NMT Preoperational, all Node
00h	80h	01h..7Fh	NMT Preoperational node number

Mode: Start

For 1 or all the nodes to switch to operational mode, the master sends the following message:

COB-ID	Command (Byte 0)	Node Number (Byte 1)	Description
00h	01h	00h	NMT Start, all Node
00h	01h	01h..7Fh	NMT Start node number

Mode: STOP

For 1 or all the nodes to switch off operational mode, the master sends the following message:

COB-ID	Command (Byte 0)	Node Number (Byte 1)	Description
00h	02h	00h	NMT Stop, all Node
00h	02h	01h..7Fh	NMT Stop node number

POSI+ CANOPEN USER MANUAL

4. Communication objects 1000h to 1FFFh (DS 301)

Introduction This section lists the objects relating to the communication. Each object, with all its technical characteristics, is described according to the CANopen standard.

EDS File : PHM5V102.EDS Standard Encoder, Device Name (1008h) = POSI+
 (EDS File : PHM5SFV102.EDS for the compatibility with old encoder SHM5,SHU9,MHM5
 Device Name = POSI+SF, not for new designs, objects description in Appendix)

Format:

U8 : Unsigned 8 bits

U16 : Unsigned 16 bits

U32 : Unsigned 32 bits

Access:

RO : Read Only

RW : Read Write

Object SubIndex	Name	Format	Access	Default	Save	Description
1000 0	DeviceType	U32	RO	multiturn 00020196h monoturn 00010196h		Encoder type: Bytes 0,1 0001:Monoturn 0002:Multiturn Profil Bytes 2,3: 0196h=406
1001 0	ErrorRegister	U8	RO	00h		Bit0 = Generic error Bit4 = Communication error
1003	pre-defined error field					Contains the last error
1003 0	Number of actual errors	U8	RW	00h		Number of stored messages 0 or 1 Write 0 to reset the counter
1003 1	New, actual error	U32	RO	#####		Last Error 1000h Generic error 8130h Life Guard error or Heartbeat error
1005 0	COB-ID SYNC Message	U32	RW	00000080h	Yes	COB ID of the sync object
1008 0	DeviceName	STR	CONST	POSI+		Name : POSI+ (standard) Name : POSI+ SF for compatibility with SHM5/MHM5 see Appendix
100C 0	GuardTime	U16	RW	0000h	Yes	Timer for nodeguarding
100D 0	LifeTimeFactor	U8	RW	00h	Yes	Multiplication of Guard time
1010	StoreParameters					Save parameters to encoder
1010 0	LargestSupportedSubindex	U8	RO	01h		No. of save possibilities 1
1010 1	SaveAllParameters	U32	RW	00000001h		="evas " (0x65766173) to save
1011	RestoreDefaultParameters					Restore default parameters from the encoder
1011 0	LargestSupportedSubindex	U8	RO	01h		No. of restore possibilities = 1

POSI+ CANOPEN USER MANUAL

1011 1	RestoreAllDefaultParameters	U32	RW	00000001h		"daol" (0x64616F6C) to load
1014 0	COB-ID EMCY	U32	RO	00000081h		COB ID of the emergency object 80h + Node ID
1016	Consumer Heartbeat Time					
1016 0	Number of entries	U8	RO	01h		
1016 1	Consumer Heartbeat Time 1	U32	RW	00000000h	Yes	Bit0..15 Consumer heartbeat in ms Bit16..23 Node-ID
1017 0	Producer HeartBeat Time	U16	RW	0000h	Yes	Producer heartbeat time in ms
1018	Identity Object					
1018 0	LargestSupportedSubindex	U8	RO	04h		
1018 1	Vendor ID	U32	RO	00000184h		Vendor no. issued by CiA
1018 2	Product code	U32	RO	354D4850h		
1018 3	Revision number	U32	RO	00010000h		Current revision number
1018 4	Serial number	U32	RO	xxxxxxxh		Unique consecutive serial number
1200	Server SDO Parameter 0					
1200 0	Number of entries	U8	RO	02h		
1200 1	COB-ID Client -> Server	U32	RO	00000601h		600h+Node ID
1200 2	COB-ID Server -> Client	U32	RO	00000581h		580h+Node ID
1800	Transmit PDO1 Communication Parameter					
1800 0	NrOfEntries	U8	RO	05h		
1800 1	COB-ID	U32	RW	00000181h	Yes	PDO ID = 180h + node ID
1800 2	TransmissionType	U8	RW	FEh	Yes	FEh=User defined, cyclical
1800 3	InhibitTime	U16	RW	0000h	Yes	minimum interval for PDO transmission multiple of 100µs.
1800 5	Event Timer	U16	RW	0000h	Yes	Cycle time in ms
1801	Transmit PDO2 Communication Parameter					
1801 0	NrOfEntries	U8	RO	05h		
1801 1	COB-ID	U32	RW	00000281h	Yes	PDO ID = 280h + node ID

POSI+ CANOPEN USER MANUAL

1801 2	TransmissionType	U8	RW	01h	Yes	01h= synchronous operation
1801 3	InhibitTime	U16	RW	0000h	Yes	minimum interval for PDO transmission multiple of 100µs.
1801 5	Event Timer	U16	RW	0000h	Yes	Cycle time in ms
1A00	Transmit PDO1 Mapping					
1A00 0	NrOfEntries	U8	RO	01h		
1A00 1	Mapped Object	U32	RO	60040020h		mapping for the PDO1 the device is able to transmit b0..b7 : object length 20h = Unsigned32 b8..b15 : sub-index (00h) b16..b31 : Index (6004h)
1A01	Transmit PDO2 Mapping					
1A01 0	NrOfEntries	U8	RO	01h		
1A01 1	Mapped Object	U32	RO	60040020h		mapping for the PDO2 the device is able to transmit b0..b7 : object length 20h = Unsigned32 b8..b15 : sub-index (00h) b16..b31 : Index (6004h)

Object 1010h: Store parameters

Description This object supports the saving of parameters in non volatile memory. In order to avoid storage of parameters by mistake, storage is only executed when the specific signature "save" is written to the Sub-Index

Characteristics The characteristics of this object are outlined in the following table:

Sub-index	Description	Dtat type	Default value	Access
0	Number of sub-indexes	UNSIGNED8	1	Ro
1	Store all parameters	UNSIGNED32	-	rw

Operation To save the parameters, the "save" character string (6576 6173h) must be written in the corresponding index:
 Information on storage functionality is read from a sub-index. The result obtained, 0000 0001h, indicates that the module saves parameters only when it receives the command to do so.

POSI+ CANOPEN USER MANUAL

Object 1011h: Restore Default parameters

Description This object is used to restore the encoder default parameters. In order to avoid the restoring of default parameters by mistake, restoring is only executed when the specific signature "load" (6461 6F6Ch) is written to the appropriate sub-index.

Characteristics The characteristics of this object are outlined in the following table:

Sub-Index	Description	Data type	Default value	Access
0	Number of sub-indexes	Unsigned8	1	Ro
1	Restore all default parameters	Unsigned32	-	rw

Note: The restoration of parameters will only be taken into account after a power up or NMT Reset. After the power on or the NMT Reset, the transmission Rate and the node number are the default values

Operation To restore the parameters, the corresponding index must be written in the "load" character string (6461 6F6Ch):

	Most significant word		Least Significant word	
ISO 8859 (ASCII) signature	d	a	o	l
Hex value	64h	61h	6Fh	6Ch

Information on whether it is possible to restore the module's factory parameters is read from a sub-index. The result obtained, 00000001h, indicates that the factory parameters can only be restored when the module receives the command to do so.

Object 1800h: 1st Transmit PDO communication Parameter

Description This object contains the Transmit PDO communication parameter.

Characteristics The characteristics of this object are outlined in the following table:

Sub-Index	Description	Data type	Default value	Access
0	Number of sub-indexes	Unsigned8	5	ro
1	COB-ID	Unsigned32	180h + Node ID	rw
2	Transmission mode	Unsigned8	FEh	rw
3	Inhibit time	Unsigned32	0	rw
4	Not available			
5	Event timer	Unsigned32	0	rw

POSI+ CANOPEN USER MANUAL

Transmission mode

The PDO transmission mode can be configured as described in the table below.

Transfer code	Transmission code					Notes
	Cyclic	Acylic	Synchronous	Asynchronous	RTR only	
0		x	x			Send PDO on first Sync message following an event
1 to 240	x		x			Send PDO every n (n=0...240) Sync messages
241 to 251	Reserved					-
252			x		x	Update data immediately after Remote request and send PDO on next SYNC message
253				x	x	Update data and send PDO on Remote Request
254				x		Send PDO on manufacturer-event
255				x		Send PDO on encoder -event

COB-ID Structure

The structure of a COB-ID for CAN2.0 is shown in the following table:

Bit No.	Value	Meaning
31 (MSB)	0	The PDO object exists
	1	The PDO object doesn't exist
30	0	RTR mechanism authorized
	1	RTR mechanism unauthorized
29	0	11-bit ID (CAN 2.0A)
28-11	0	If bit 29 = 0
10-0 (LSB)	X	Bit 10-0 of the identifier

Inhibit Time (Sub-index 3)

For "Transmit PDOs", the "inhibit time" for PDO transmissions can be entered in this 16 bit field. If data is changed, the PDO sender checks whether an "inhibit time" has expired since the last transmission. A new PDO transmission can only take place if the "inhibit time" has expired. The "inhibit time" is useful for asynchronous transmission (transmission mode 254, 255), to avoid overloads on the CAN bus. The "inhibit time" is a multiple of 100µs of object 1800sub03/1801sub03.

POSI+ CANOPEN USER MANUAL

Event Timer (Sub-index 5)

In mode 254/255, if a value > 0 is written in this 16-bit field, the TPDO is always sent after the "event timer" expires. The value written in 1800sub05 and 1801sub05 corresponds to the "event timer" in ms.

Object 1801h: 2nd Transmit PDO communication Parameter

Description This object contains the Transmit PDO communication parameter.

Characteristics The characteristics of this object are outlined in the following table:

Sub-Index	Description	Data type	Default value	Access
0	Number of sub-indexes	UNSIGNED8	5	Ro
1	COD-ID	UNSIGNED32	280h+node ID	Rw
2	Transmission mode	UNSIGNED8	1	Rw
3	Inhibit time	UNSIGNED16	0	Rw
4	Not available			
5	Event timer	UNSIGNED16	0	Rw

POSI+ CANOPEN USER MANUAL

5 Manufacturer-specific objects 2000h to 5FFFh

Object SubIndex	Name	Format	Access	Default	Save	Description
2002 0	Speed	I16	RO		No	Speed of the encoder shaft Number of physical impulses with a time period of 5 ms
2005	PDO-Type	U8	RW	00h	Yes (1.02)	Types for PDO1 and PDO2 Bit 3..0 = PDO1 Bit 7..4=PDO 2 0 (Default):Byte 0 .. Byte3 of PDO = Value of position 2 (Type 2):Byte 0 .. Byte3 of PDO = Value of position Byte 4 .. 5 of PDO = Speed Byte 6 .. 7 of PDO = 0x00 0x00
2100 0	Transmission Rate	U8	RW	01h	Yes	After setting the baud rate, the EEPROM must be saved and reinitialized 0=10 kBit/s 1=20 kBit/s (default) 2=50 kBit/s 3=100 kBit/s 4=125 kBit/s 5=250 kBit/s 6=500 kBit/s 7=800 kBit/s 8=1000 kBit/s
2101 0	Node Number	U8	RW	01h	Yes	Node number 1..127 possible After setting the baud rate, the EEPROM must be saved and reinitialized.

Object 2002h: Speed

Only for standard encoder with software version >=1.01 : DeviceName (1008h) = « POSI+ » , Software Version (6507h) >= 0x0101

CMS	Index	Default value	Value range	Data length
SDO	2002h			Signed 16

Description To measure the rotational speed of the encoder shaft, the difference between two physical (unscaled) values of position with a time period of 5 ms is calculated. The difference between the two values will be read out as a signed 16 bits value (positive value = clockwise direction of rotation).

The output of the speed by means of PDO is made possible by setting the desired PDOs to type 2 (see object 2005h).

Object 2005h: PDO Type

Only for standard encoder with software version >=1.01 : DeviceName (1008h) = « POSI+ » , Software Version (6507h) >= 0x0101

CMS	Index	Default value	Value range	Data length
SDO	2005h	00h		Unsigned 8

This object helps to determine the types for PDO1 and PDO2.

POSI+ CANOPEN USER MANUAL

The COB ID and the transfer type for the PDOs is determined in the objects 1800h and 1802h.

With the software version = 1.01, this value cannot be stored in the EEPROM and has to be transferred again after each activation (Reset or Power-On).

With the software version >=1.02, this value can be stored in the EEPROM.

Data	Bit 7 .. 4 = PDO2	Bit 3 .. 0 = PDO1
00h	Default	Default
02h	Default	Type2
20h	Type2	Default
22h	Type2	Type2

Standard: PDO1 and PDO2 set to type Default (00h)

COB-ID	Process data (PDO)								
	11 bit	Byte 0	Byte 1	Byte 2	Byte 3	Byte 4	Byte 5	Byte 6	Byte 7
Default		Value of position							
Type 2		Value of position				Speed	00h 00h		

Object 2100h: Transmission Rate

Only for standard encoder : DeviceName (1008h) = « POSI+ »

Description This object contains the baud rate, see table above for the values.

Default = 20kbit/s

Object 2101h: Node Number

Only for standard encoder : DeviceName (1008h) = « POSI+ »

Description This object contains the Node Number.

Default = 1

Note: After setting the baud rate or the node number, the parameters must be saved in the EEPROM with "StoreParameters" (Object 1010h) and the new values are set valid after the device is reset (NMT reset node) or power cycled.

POSI+ CANOPEN USER MANUAL

6. Encoder-specific objects 6000h to 9FFFh (DS 406)

Introduction This section lists the encoder-specific objects. Each object, with all its technical characteristics, is described according to the CANopen standard.

Object SubIndex	Name	Format	Access	Default	Save	Description
6000 0	Operating Parameters	U16	RW	0004h	Yes	Bit0 = Position increasing 0 CW 1 CCW Bit2 = 0 Scaling function disabled 1 Scaling function enabled
6001 0	Measuring Units per Revolution	U32	RW	00002000h	Yes	Resolution in steps / revolution: 13 bits
6002 0	Total Measuring Range	U32	RW	Multi: 20000000h Mono: 00002000h	Yes	Overall measuring range in increments 29Bit = multiturn 13Bit = singleturn
6003 0	Preset Value	U32	RW	00000000h	Yes	Preset in increments
6004 0	Position Value	U32	RO	00000ECBh		Position value
6200 0	Cyclic timer	U16	RW	0000h	Yes	In ms, identical object 1800h, subindex 5
6300	Cam state register					
6300 0	NrOfAvailableChannel	U8	RO	01h		only CAM1
6300 1	Cam state channel 1	U8	RO	00h		status bit of the cam in a cam channel Bit0 = CAM1 0 = CAM inactive 1 = CAM active
6301	Cam enable					
6301 0	NrOfAvailableChannel	U8	RO	01h		only CAM1
6301 1	Cam enable channel 1	U8	RW	00h	Yes	Bit0 = CAM1 0 = cam disable 1 = cam state calculated by the device
6302	Cam polarity					
6302 0	NrOfAvailableChannel	U8	RO	01h		
6302 1	Cam polarity channel 1	U8	RW	00h	Yes	Bit0 = CAM1 0 = cam state not inverted 1 = cam state not inverted
6310	Cam1 low limit					

POSI+ CANOPEN USER MANUAL

6310 0	NrOfAvailableChannel	U8	RO	01h		only CAM1
6310 1	Cam1 low limit channel 1	U32	RW	00000000h	Yes	switch point for the lower limit setting for CAM1
6320	Cam1 high limit					
6320 0	NrOfAvailableChannel	U8	RO	01h		only CAM1
6320 1	Cam1 high limit channel 1	U32	RW	00000000h	Yes	switch point for the higher limit setting for CAM1
6500 0	Operating Status	U16	RO	0004h		Bit0 = Position increasing 0 CW 1 CCW Bit2 = 0 Scaling function disabled 1 Scaling function enabled
6501 0	Single Turn Resolution	U32	RO	00002000h		Max. Resolution in steps / revolution: 13 bits
6502 0	Number of Revolutions	U16	RO	Multi FFFFh Mono 0001h		Number of distinguishable revolutions Multiturn = FFFFh Monoturn = 1
6503 0	Alarms	U16	RO	0000h		Alarms
6504 0	Supported Alarms	U16	RO	0000h		Supported Alarms
6505 0	Warnings	U16	RO	0000h		Warnings
6506 0	Supported Warnings	U16	RO	0000h		Supported Warnings
6507 0	Profile & Software Version	U32	RO	01020301h		Byte 0,1: Profile version = 3.1 = 0301h Byte 2,3: Software version = 1.02 = 0102h
6508 0	Operating Time	U32	RO	FFFFFFFFh		not used
6509 0	Calculated Offset Value	INT32	RO			Offset calculated from preset 6003h
650A	Module Identification					
650A 0	NrOfEntries	U8	RO	03h		
650A 1	manufacturer_offset_value	U32	RO	00000000h		Manufacturer offset value
650A 2	Manufacturer_Min_Position_Value	U32	RO	00000000h		Minimum position value
650A 3	Manufacturer_Max_Position_Value	U32	RO	Multi: 1FFFFFFFh Mono: 00001FFFh		Maximum position value
650B 0	Serial Number	U32	RO			Linked with serial number object 1018-4

POSI+ CANOPEN USER MANUAL

Object 6000h: Operating Parameters

Presentation The code sequence (Complement) can be selected as the operating parameter.

CMS	Index	Default value	Value range	Data length
SDO	6000h	0h	0h-FFFFh	Unsigned 16

Bit	Function	Bit = 0	Bit = 1
0	Code Sequence	CW	CCW
1	Commissioning Diagnostic control	Not used	
2	Scaling function control	Disabled	Enabled
3	Measuring direction	Not used	

CODE SEQUENCE: The code sequence defines whether increasing or decreasing position values are output when the encoder shaft rotates clockwise or counterclockwise as seen on the shaft.

SCALING FUNCTION CONTROL: With the scaling function the encoder numerical value is converted in software to change the physical resolution of the encoder.

The measuring units per revolution object (6001h) and total measuring range in measuring units object (6002h) are the scaling parameters. The scaling function bit is set in the operating parameters. **If the scaling function bit is set to zero, the scaling function is disabled.**

Object 6001h: Measuring Units per revolution

Presentation The Measuring Units per revolution parameter is used to program the required number of steps per revolution. Choose a value between 2 and 8192:

CMS	Index	Default value	Value range	Data length
SDO	6001h	-	0h – 2000h	Unsigned 16

Object 6002h: Total measuring range in measuring units

Presentation This parameter is used to program the required number of measuring units from the global measuring range. This value must not exceed that of the total resolution of the absolute rotary encoder

CMS	Index	Default value	Value range	Data length
SDO	6002h	2000 0000h	2 - 2000 0000h	Unsigned 32

Total measuring range (total resolution) = Number of revolutions x · Measuring Units per resolution

POSI+ CANOPEN USER MANUAL

Object 6003h: Preset Value

Presentation The preset value is the required position value to be reached at a certain physical location of the axis. The position value is fixed as being the process value required by the presetting of the parameters.

To avoid execution time errors, the preset value must not exceed the total measuring range (total resolution) -1 of the parameters.

CMS	Index	Default value	Value range	Data length
SDO	6003h	-	0 – (total resolution-1)	Unsigned 32

Object 6004h: Position Value

Description This object is used to define the position of the encoder.

CMS	Index	Default value	Value range	Data length
SDO	6004h	-	0 – (total resolution-1)	Unsigned 32

Object 6200h: Cyclic Timer

Cyclic mode The absolute rotary encoder transmits the current process value cyclically – without being polled by the host. The cycle time can be programmed in milliseconds for values between 1 ms and 65535 ms. (For example: 64h = 100 ms).

CMS	Index	Default value	Value Range	Data length
SDO	6200h	0h	0h – FFFFh	Unsigned 16

This parameter is identical "Event Timer" of the transmit PDO1 Index 1800h, Sub Index 05h.

See description of the object "Transmit PDO1" (1800h) for the use of the cyclic timer.

If the value is 0, the cyclic timer is disabled and the position is never sent.

Note: After setting the encoder parameters, they must be saved in the EEPROM with "StoreParameters" (Object 1010h). If the encoder parameters are not saved, the configuration will be lost at the next power up.

POSI+ CANOPEN USER MANUAL

Object 6500h: Operating Status

Description This object contains the operating status of the encoder. It provides information on the encoder internal parameters.

Values The values of this object are outlined in the following table:

Bit	Function	Value = 0	Value = 1
0	Code sequence	CW	CCW
1	Commissioning Diagnostic Control	Not supported	Supported
2	Scaling function control	Disabled	Enabled
3	Measuring direction	Not used	
4...11	Reserved		
12	Manufacturer specific alarm	Not used	
13	Manufacturer specific alarm	Not used	
14	Manufacturer specific alarm	Not used	
15	Manufacturer specific alarm	Not used	

CMS	Index	Sub Index	Default value	Value range	Data length	Access
SDO	6500h	00h	-	-	Unsigned 16	ro

Object 6501h: Singleturn Resolution (Rotary)

Description This object indicates the number of steps per revolution according to the position of the encoder. The maximum encoder resolution is 8192.

CMS	Index	Sub Index	Default value	Value range	Data length	Access
SDO	6501h	00h	2000h	-	Unsigned 32	ro

Object 6502h: Number of Distinguishable Revolutions

Description This object indicates the number of revolutions that the encoder can execute. The maximum number of revolutions of the encoder is 65536.

CMS	Index	Sub Index	Default value	Value range	Data length	Access
SDO	6502h	00h	FFFFh	-	Unsigned 16	ro

POSI+ CANOPEN USER MANUAL

Object 6503h: Alarms

Description This object contains the various alarm messages. An alarm will be displayed if a malfunction of the encoder cause a position error. The alarm bit remains enabled until the alarm is cleared and the encoder is able to provide a correct position value.

Values The values of this object are outlined in the following table:

Bit	Function	Value = 0	Value = 1
0	Position error	No	Yes
1	Commissioning diagnostics	Not supported	Supported
2...11	Reserved		
12	Manufacturer specific alarm	Disabled	Enabled
13	Manufacturer specific alarm	Disabled	Enabled
14	Manufacturer specific alarm	Disabled	Enabled
15	Manufacturer specific alarm	Disabled	Enabled

Object 6504h: Supported Alarms

Description This object indicates the alarms supported by the encoder.

Values The values of this object are outlined in the following table:

Bit	Function	Value = 0	Value = 1
0	Position error	No	Yes
1	Commissioning diagnostics	No	Yes
2...11	Reserved		
12	Manufacturer specific alarm	No	Yes
13	Manufacturer specific alarm	No	Yes
14	Manufacturer specific alarm	No	Yes
15	Manufacturer specific alarm	No	Yes

POSI+ CANOPEN USER MANUAL

Object 6505h: Warnings

Description This object indicates if the tolerances of certain encoder internal parameters have been exceeded

Values The values of this object are outlined in the following table:

Bit	Function	Value = 0	Value = 1
0	Position error	No	Yes
1	Ligth control reverse	Not reached	Error
2	CPU watchdog status	OK	Reset
3	Operating time limit warning	No	Yes
4	Battery charge	OK	Too slow
5	Reference point	Reached	Not reached
6...11	Reserved		
12	Manufacturer specific warning	N/A	N/A
13	Manufacturer specific warning	N/A	N/A
14	Manufacturer specific warning	N/A	N/A
15	Manufacturer specific warning	N/A	N/A

Object 6506h: Supported Warnings

Description This object indicates the warnings supported by the encoder.

Values The values of this object are outlined in the following table:

Bit	Function	Value = 0	Value = 1
0	Frequency exceed	Not supported	Supported
1	Light control reverse	Not supported	Supported
2	CPU watchdog status	Not supported	Supported
3	Operating time limit warning	Not supported	Supported
4	Battery charge	Not supported	Supported
5	Reference point	Not supported	Supported
6...11	Reserved	Not supported	Supported
12	Manufacturer-specific warning	Not supported	Supported
13	Manufacturer-specific warning	Not supported	Supported
14	Manufacturer-specific warning	Not supported	Supported
15	Manufacturer-specific warning	Not supported	Supported

POSI+ CANOPEN USER MANUAL

Object 6507h: Profile and Software Version

Description This object indicates the encoder hardware profile version and software version.

Object 6508h: Operating Time

Description This object indicates the encoder operating time. The operating time is recorded in the EEPROM memory as long as the encoder is powered up.

This function is not available for this encoder. The delivered value is FFFFFFFh.

Object 6509h: Offset Value

Description This object indicates the offset value. The offset value is calculated by the Preset value function (see *Object 6003h: Preset Value, p. 83*). It is then used by the encoder to offset the position value.

The offset value is recorded and can be read in the encoder.

Object 650Ah: Module identification

Description This object indicates the manufacturer-specific offset value, as well as the minimum and maximum position values.

The offset value is stored in sub-index 1.

The minimum and maximum position values are stored in sub-indices 2 and 3 respectively.

Characteristics The characteristics of this object are outlined in the following table:

Sub-Index	Description	Data type	Default value	Access
0	Number of inputs	Unsigned 32		ro
1	Manufacturer offset value	Unsigned 32	0h	Ro
2	Manufacturer minimum value	Unsigned 32		Ro
3	Manufacturer maximum position value	Unsigned 32		ro

Object 650Bh: Serial Number

Description This object indicates the encoder serial number.

Linked with serial number object 1018-4.

POSI+ CANOPEN USER MANUAL

Encoder Cam1 :

Only for standard encoder : DeviceName (1008h) = « POSI+ »

Only one CAM is available.

Cam1 has parameters for the minimum switch point, the maximum switch point.

The encoder calculates the cam state if the bit0 of the Object "Cam Enable" channel 1 (Index 6301h Sub Index 01h) is set to 1.

Low limit of CAM1 : Object "Cam1_low_limit_channel_1" (Index 6310h Sub Index 01h)

High limit of CAM1 : Object "Cam1_high_limit_channel_1" (Index 6320h Sub Index 01h)

Polarity of CAM1 : bit0 Index 6302h Sub Index 01h

If the polarity bit is set to 1, the cam state of an active cam shall signal by setting the related cam state bit to zero. In the other case the cam state of the related cam shall not be inverted.

State of CAM1 : Object "Cam_state_channel_1" Index 6300h Sub Index 01h

The status bit set to 1 shall define "cam active". The status bit set to 0 shall define "cam inactive".

If the polarity bit of a cam is set (refer to index 6302h Sub Index 01h) the actual cam state will be inverted.

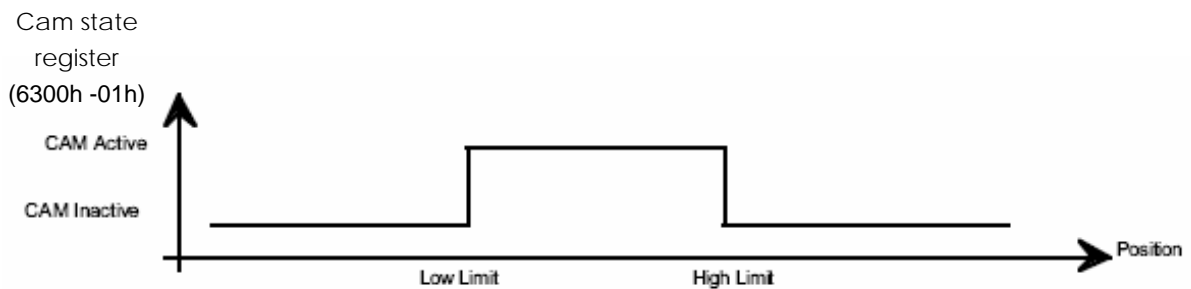

polarity bit is set to 0 (6302h -01)

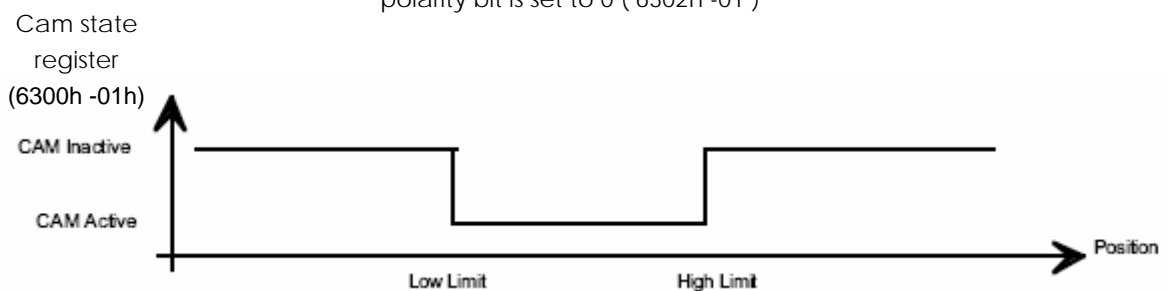

polarity bit is set to 1 (6302h -01)

Nota: The ESD can be downloaded free of charge from our Homepage www.bei-ideacod.com.

We do not assume responsibility for technical inaccuracies or omissions. Specifications are subject to change without notice.

POSI+ CANOPEN USER MANUAL

Appendix

Software for the compatibility with with the old encoders SHM5/SHU9/CHU9/MHM5
 Do not use this version for the new designs only to replace old encoders.
 EDS File: PHM5SFV102.EDS

Device Name (0x1008) = "POSI+ SF" for this version and the following objects are supported
 See the SHM5 / MHM5 Manual for the complete description of these objects.

Object SubIndex	Name	Format	Access	Default	Save	Description
1000 0	DeviceType	U32	RO	multiturn 00020196h monoturn 00010196h		
1001 0	ErrorRegister	U8	RO	00h		
1018	Identity Object					
1018 0	LargestSupportedSubindex	U8	RO	04h		
1018 1	Vendor ID	U32	RO	00000184h		
1018 2	Product code	U32	RO	354D4850h		
1018 3	Revision number	U32	RO	00010000h		
1018 4	Serial number	U32	RO	xxxxxxxh		
1003	pre-defined error field					
1003 0	Number of actual errors	U8	RW	00h		
1003 1	New, actual error	U32	RO	#####		
1004	Number of PDOs supported					
1004 0	Number of PDOs supported	U32	RO	00000002h		
1004 1	Number of synchronous PDOs	U32	RO	00000001h		
1004 2	Number of asynchronous PDOs	U32	RO	00000001h		
1005 0	COB-ID SYNC Message	U32	RW	00000080h	Yes	
1008 0	DeviceName	STR	CONST	POSI+ SF		
100C 0	GuardTime	U16	RW	0000h	Yes	
100D 0	LifeTimeFactor	U8	RW	00h	Yes	
100F 0	number of SDOs supported	U32	RO	00000001h		

POSI+ CANOPEN USER MANUAL

1010	StoreParameters					
1010 0	LargestSupportedSubindex	U8	RO	01h		
1010 1	SaveAllParameters	U32	RW	00000001h		
1011	RestoreDefaultParameters					
1011 0	LargestSupportedSubindex	U8	RO	01h		
1011 1	RestoreAllDefaultParameters	U32	RW	00000001h		
1014 0	COB-ID EMCY	U32	RO	00000081h		
1016	Consumer Heartbeat Time					
1016 0	Number of entries	U8	RO	01h		
1016 1	Consumer Heartbeat Time 1	U32	RW	00000000h	Yes	
1017 0	Producer HeartBeat Time	U16	RW	0000h	Yes	
1200	Server SDO Parameter 0					
1200 0	Number of entries	U8	RO	02h		
1200 1	COB-ID Client -> Server	U32	RO	00000601h		
1200 2	COB-ID Server -> Client	U32	RO	00000581h		
1800	Transmit PDO1 Communication Parameter					
1800 0	NrOfEntries	U8	RO	05h		
1800 1	COB-ID	U32	RW	00000181h	Yes	
1800 2	TransmissionType	U8	RW	FEh	Yes	
1800 3	InhibitTime	U16	RW	0000h	Yes	
1800 5	Event Timer	U16	RW	0000h	Yes	
1801	Transmit PDO2 Communication Parameter					
1801 0	NrOfEntries	U8	RO	05h		
1801 1	COB-ID	U32	RW	00000281h	Yes	
1801 2	TransmissionType	U8	RW	01h	Yes	
1801 3	InhibitTime	U16	RW	0000h	Yes	

POSI+ CANOPEN USER MANUAL

1801 5	Event Timer	U16	RW	0000h	Yes	
1A00	Transmit PDO1 Mapping					
1A00 0	NrOfEntries	U8	RO	01h		
1A00 1	Mapped Object	U32	RO	60040020h		
1A01	Transmit PDO2 Mapping					
1A01 0	NrOfEntries	U8	RO	01h		
1A01 1	Mapped Object	U32	RO	60040020h		
6000 0	Operating Parameters	U16	RW	0004h	Yes	
6001 0	Measuring Units per Revolution	U32	RW	00002000h	Yes	
6002 0	Total Measuring Range	U32	RW	Multi: 20000000h Mono: 00002000h	Yes	
6003 0	Preset Value	U32	RW	00000000h	Yes	
6004 0	Position Value	U32	RO	1FFFFDE6h		
6005 0	Limit Switch Min	U32	RW	00000000h	Yes	
6006 0	Limit Switch Max	U32	RW	00000000h	Yes	
6100 0	Transmission Rate	U16	RW	0002h	Yes	
6101 0	Node Number	U16	RW	0001h	Yes	
6200 0	Cyclic timer	U16	RW	0000h	Yes	
6500 0	Operating Status	U16	RO	0004h		
6501 0	Single Turn Resolution	U32	RO	00002000h		
6502 0	Number of Revolutions	U16	RO	Multi FFFFh Mono 0001h		
6503 0	Alarms	U16	RO	0000h		
6504 0	Supported Alarms	U16	RO	0000h		
6505 0	Warnings	U16	RO	0000h		
6506 0	Supported Warnings	U16	RO	0000h		

POSI+ CANOPEN USER MANUAL

6507 0	Profile Version	U32	RO	01020301h		
6508 0	Operating Time	U32	RO	FFFFFFFFh		
6509 0	Calculated Offset Value	INT32	RO	00000000h		
650A	Module Identification					
650A 0	Manufacturer Offset Value	INT32	RO	00000000h		
650A 1	Manufacturer Minimum Position Value	INT32	RO	00000000h		
650A 2	Manufacturer Maximum Position Value	INT32	RO	Multi: 1FFFFFFFh Mono: 00001FFFh		
650B 0	Serial Number	U32	RO	12345678h		
2000 0	Process Value	U32	RO	1FFFDE6h		
2100 0	Operating Parameter	U16	RW	0000h	Yes	
2101 0	Resolution per Revolution	U16	RW	2000h	Yes	
2102 0	Total Resolution	U32	RW	20000000h	Yes	
2103 0	Preset Value	U32	RW	00000000h	Yes	
2104 0	Limit Switch Min	U32	RW	00000000h	Yes	
2105 0	Limit Switch Max	U32	RW	00000000h	Yes	
2200 0	Cyclic Time	U16	RW	0000h	Yes	
2300 0	Save Parameter	U32	WO	#####		
3000 0	C5 Node number	U8	RW	01h	Yes	
3001 0	C5 Baud Rate	U8	RW	00h	Yes	