

SEKISUI

ESLON VALVE

**Automatic Operation Valves
&
Sensors**

Printed 2006/09

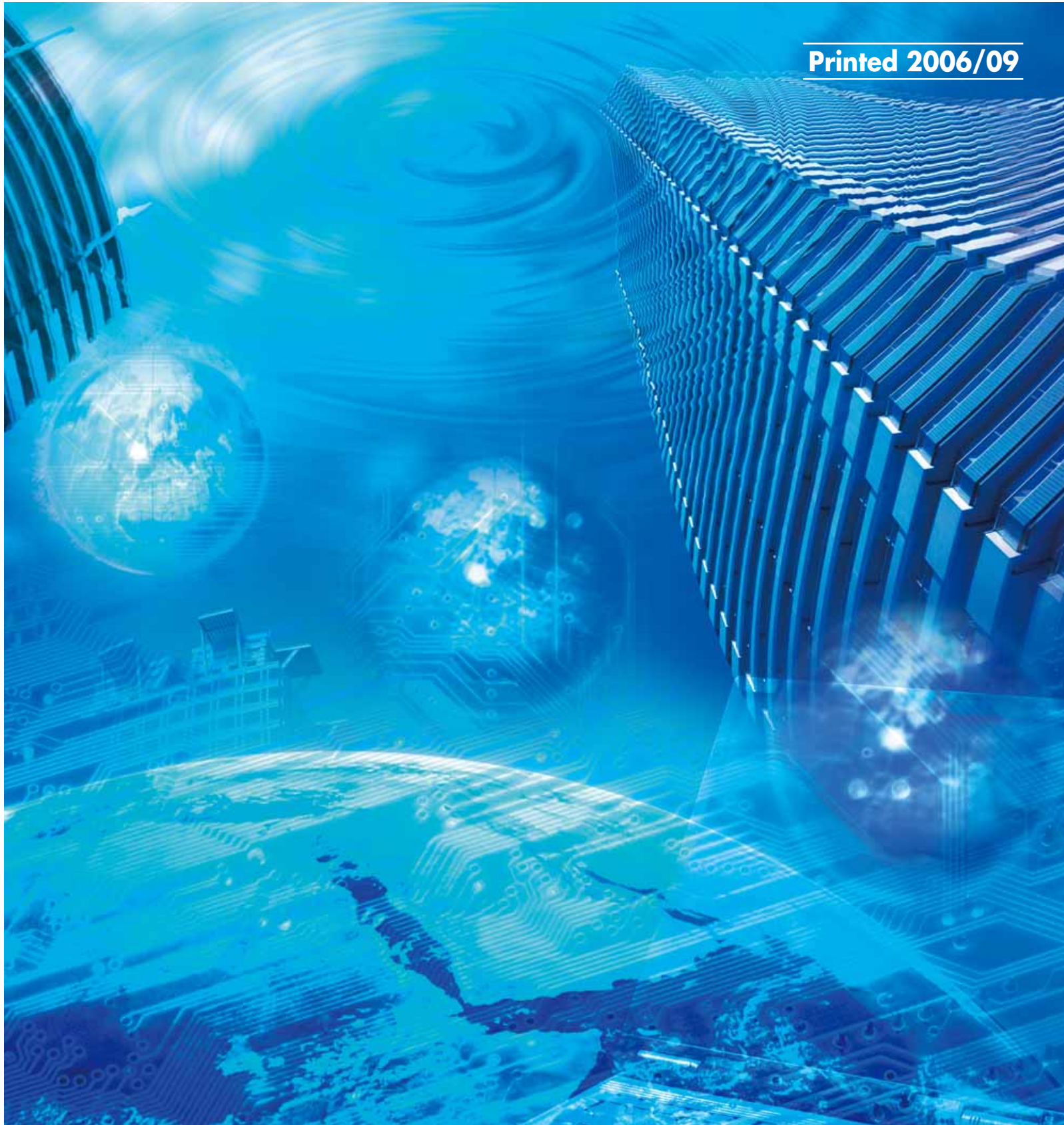

ESLON VALEVE

Automatic Operation Valves & Sensors

- Product list 3
- Basic Notes 6
- Pneumatic Valve I
- Electric Valve II
- Solenoid Valve III
- Sensor IV
- Technical Information ... V

Pneumatic valve

I-1 ▶▶ I-5

PNEUMATIC DIAPHRAGM VALVE TYPE B



Size:15~100
Material:PVC, HT, PP, PVDF ▶▶ I-1

PNEUMATIC DIAPHRAGM VALVE TYPE D



Size:15~100
Material:PVC, HT, PP, PVDF ▶▶ I-2

PNEUMATIC BALL VALVE TYPE C



Size:15~100
Material:PVC, HT, PP, PVDF ▶▶ I-3

PNEUMATIC BUTTERFLY VALVE



Size:40~300
Material:PVC, GF-PP ▶▶ I-4



Electric valve

II-1 ▶▶ II-12

ELECTRIC DIAPHRAGM VALVE TYPE KS



Size:15~150
Material:PVC, HT, PP, PVDF ▶▶ II-1

ELECTRIC BALL VALVE TYPE K



Size:15~100
Material:PVC, HT, PP, PVDF ▶▶ II-2

ELECTRIC BALL VALVE TYPE N



Size:15~100
Material:PVC, HT, PP, PVDF ▶▶ II-3

ELECTRIC BALL VALVE TYPE KS



Size:15~100
Material:PVC, HT, PP, PVDF ▶▶ II-4

ELECTRIC YP BALL VALVE



Size:15~50
Material:PVC ▶▶ II-5

3-WAY BALL VALVE



Size:15~50
Material:PVC ▶▶ II-6

ELECTRIC BUTTERFLY VALVE TYPE K



Size:40~300
Material:PVC, GF-PP ▶▶ II-7

ELECTRIC BUTTERFLY VALVE TYPE N



Size:40~300
Material:PVC, GF-PP ▶▶ II-8

ELECTRIC BUTTERFLY VALVE TYPE KS



Size:40~300
Material:PVC, GF-PP ▶▶ II-9

Solenoid valve

Plastic solenoid Valve which has excellent corrosion resistance

III-1 >> III-4

SOLENOID VALVE TYPE 121



Material:PVC, PVDF

>> III-1

SOLENOID VALVE TYPE 131



Size:13~20
Material:PVC, PVDF

>> III-2

SOLENOID VALVE TYPE 142



Size:15~50
Material:PVC, PVDF

>> III-3

SOLENOID VALVE TYPE 6228



Size:13, 15
Material:PPE, PA

>> III-4

Sensor

Measurement of flow rate, liquid-level, pH, ORP and electric conductivity

IV-1 >> IV-10

FLOW SENSOR TYPE 8030
TYPE 8035



Size:15~50
Material:PVC, PP, PVDF

>> IV-1

FLOW SENSOR TYPE 8020
TYPE 8025



Size:65~100
Material:PVC, PP, PVDF

>> IV-3

FLOW SENSOR TYPE 8034



Size:15~50
Material:PVC, PP, PVDF

>> IV-4

FLOW SENSOR TYPE 8031



Material:ECTFE

>> IV-5

FLOW SENSOR TYPE 8045



Size:15~50
Material:PVC, PP, PVDF

>> IV-6

PH SENSOR TYPE 8025



Size:15~50
Material:PVC, PP, PVDF

>> IV-7

ORP SENSOR TYPE 8026



Size:15~50
Material:PVC, PP, PVDF

>> IV-8

CONDUCTIVITY SENSOR
TYPE 8225



Size:32~50
Material:PVC, PP, PVDF

>> IV-9

ULTRASONIC LEVEL SENSOR
TYPE 8175



Material:PVDF

>> IV-10

ESLON VALVE Automatic Operation Product List

PNEUMATIC

■ PNEUMATIC DIAPHRAGM VALVE TYPE B (P. I -1)

Material	PVC			HT (CPVC)		PP	PVDF		
Operation	Double&Normal&Reverse action	Double&Normal&Reverse action	Double&Normal&Reverse action	Double&Normal&Reverse action	Double&Normal&Reverse action	Double&Normal&Reverse action	Double&Normal&Reverse action	Double&Normal&Reverse action	Double&Normal&Reverse action
Size	Flange	Thread	TS	Flange	TS	Flange	Flange	Thread	Butt
15 (1/2)	●	●	●	●	●	●	●	●	●
20 (3/4)	●	●	●	●	●	●	●	●	●
25 (1)	●	●	●	●	●	●	●	●	●
32 (1 1/4)	●*	—	●	●	●	●	●	—	—
40 (1 1/2)	●	●	●	●	●	●	●	●	●
50 (2)	●	●	●	●	●	●	●	●	●
65 (2 1/2)	●	—	—	●	—	●	●	—	—
80 (3)	●	—	—	●	—	●	●	—	—
100 (4)	●	—	—	●	—	●	●	—	—

※32A flange type has the same body as 40A and long bolt holes.

■ PNEUMATIC DIAPHRAGM VALVE TYPE D (P. I -2)

Material	PVC			HT (CPVC)		PP	PVDF		
Operation	Double&Normal&Reverse action	Double&Normal&Reverse action	Double&Normal&Reverse action	Double&Normal&Reverse action	Double&Normal&Reverse action	Double&Normal&Reverse action	Double&Normal&Reverse action	Double&Normal&Reverse action	Double&Normal&Reverse action
Size	Flange	Thread	TS	Flange	TS	Flange	Flange	Thread	Butt
15 (1/2)	●	●	●	●	●	●	●	●	●
20 (3/4)	●	●	●	●	●	●	●	●	●
25 (1)	●	●	●	●	●	●	●	●	●
32 (1 1/4)	●	—	●	●	●	●	●	—	—
40 (1 1/2)	●	●	●	●	●	●	●	●	●
50 (2)	●	●	●	●	●	●	●	●	●
65 (2 1/2)	●	—	—	●	—	●	●	—	—
80 (3)	●	—	—	●	—	●	●	—	—
100 (4)	●	—	—	●	—	●	●	—	—

■ PNEUMATIC BALL VALVE TYPE C (P. I -3)

Material	PVC			HT (CPVC)		PP	PVDF		
Operation	Double&Normal&Reverse action	Double&Normal&Reverse action	Double&Normal&Reverse action	Double&Normal&Reverse action	Double&Normal&Reverse action	Double&Normal&Reverse action	Double&Normal&Reverse action	Double&Normal&Reverse action	Double&Normal&Reverse action
Size	Flange	Thread	TS	Flange	TS	Flange	Flange	Thread	Butt
15 (1/2)	●	●	●	●	●	●	●	●	●
20 (3/4)	●	●	●	●	●	●	●	●	●
25 (1)	●	●	●	●	●	●	●	●	●
32 (1 1/4)	●	●	●	●	●	●	●	●	●
40 (1 1/2)	●	●	●	●	●	●	●	●	●
50 (2)	●	●	●	●	●	●	●	●	●
65 (2 1/2)	●	●	●	●	●	—	—	—	—
80 (3)	●	●	●	●	●	—	—	—	—
100 (4)	●	●	●	●	●	—	—	—	—

■ PNEUMATIC BUTTERFLY VALVE (P. I -4)

Material	PVC		GF-PP	
Size \ Operation	Double action	Normal&Reverse action	Double action	Normal&Reverse action
40 (1 1/2)	●	●	●	●
50 (2)	●	●	●	●
65 (2 1/2)	●	●	●	●
80 (3)	●	●	●	●
100 (4)	●	●	●	●
125 (5)	●	●	●	●
150 (6)	●	●	●	●
200 (8)	●	●	●	●
250 (10)	●	—	●	—
300 (12)	●	—	●	—

ELECTRIC

■ ELECTRIC DIAPHRAGM VALVE TYPE KS (P. II -1)

Power supply voltage	AC100V/200V						
Material	PVC			HT (CPVC)		PP	PVDF
Size	Flange	Thread	TS	Flange	TS	Flange	Flange
15 (1/2)	●	●	●	●	●	●	●
20 (3/4)	●	●	●	●	●	●	●
25 (1)	●	●	●	●	●	●	●
32 (1 1/4)	●*	—	●	●	●	●	●
40 (1 1/2)	●	●	●	●	●	●	●
50 (2)	●	●	●	●	●	●	●
65 (2 1/2)	●	—	—	●	—	●	●
80 (3)	●	—	—	●	—	●	●
100 (4)	●	—	—	●	—	●	●
125 (5)	●	—	—	—	—	●	—
150 (6)	●	—	—	—	—	●	—

※32A flange type has the same body as 40A and long bolt holes.

■ ELECTRIC BALL VALVE TYPE K (P. II -2)

Power supply voltage	AC100V/200V								
Material	PVC			HT (CPVC)		PP	PVDF		
Size	Flange	Thread	TS	Flange	TS	Flange	Flange	Thread	Butt
15 (1/2)	●	●	●	●	●	●	●	●	●
20 (3/4)	●	●	●	●	●	●	●	●	●
25 (1)	●	●	●	●	●	●	●	●	●
32 (1 1/4)	●	●	●	●	●	●	●	●	●
40 (1 1/2)	●	●	●	●	●	●	●	●	●
50 (2)	●	●	●	●	●	●	●	●	●
65 (2 1/2)	●	●	●	●	●	—	—	—	—
80 (3)	●	●	●	●	●	—	—	—	—
100 (4)	●	●	●	●	●	—	—	—	—

■ ELECTRIC BALL VALVE TYPE N (Standard Type 15~40A, Higher Speed Type 15~100A (P. II -3))

Power supply voltage	AC100V/200V etc								
Material	PVC			HT (CPVC)		PP	PVDF		
Size	Flange	Thread	TS	Flange	TS	Flange	Flange	Thread	Butt
15 (1/2)	●	●	●	●	●	●	●	●	●
20 (3/4)	●	●	●	●	●	●	●	●	●
25 (1)	●	●	●	●	●	●	●	●	●
32 (1 1/4)	●	●	●	●	●	●	●	●	●
40 (1 1/2)	●	●	●	●	●	●	●	●	●
50 (2)	●	●	●	●	●	●	●	●	●
65 (2 1/2)	●	●	●	●	●	—	—	—	—
80 (3)	●	●	●	●	●	—	—	—	—
100 (4)	●	●	●	●	●	—	—	—	—

■ ELECTRIC BALL VALVE TYPE KS (P. II -4)

Power supply voltage	AC100V/200V etc								
Material	PVC			HT (CPVC)		PP	PVDF		
Size	Flange	Thread	TS	Flange	TS	Flange	Flange	Thread	Butt
15 (1/2)	●	●	●	●	●	●	●	●	●
20 (3/4)	●	●	●	●	●	●	●	●	●
25 (1)	●	●	●	●	●	●	●	●	●
32 (1 1/4)	●	●	●	●	●	●	●	●	●
40 (1 1/2)	●	●	●	●	●	●	●	●	●
50 (2)	●	●	●	●	●	●	●	●	●
65 (2 1/2)	●	●	●	●	●	—	—	—	—
80 (3)	●	●	●	●	●	—	—	—	—
100 (4)	●	●	●	●	●	—	—	—	—

■ ELECTRIC YP BALL VALVE (P. II -5)

Power supply voltage	DC24V		
Material	PVC		
Size	Flange	Thread	TS
15 (1/2)	●	●	●
20 (3/4)	●	●	●
25 (1)	●	●	●
32 (1 1/4)	●	●	●
40 (1 1/2)	●	●	●
50 (2)	●	●	●

■ 3-WAY BALL VALVE (P. II -6)

Power supply voltage	AC100V/200V		
Material	PVC		
Size	Flange	Thread	TS
15 (1/2)	●	●	●
20 (3/4)	●	●	●
25 (1)	●	●	●
40 (1 1/2)	●	●	●
50 (2)	●	●	●

■ ELECTRIC BUTTERFLY VALVE TYPE K (P. II -7)

Power supply voltage	AC100V/200V	
Size \ Material	PVC	GF-PP
40 (1 1/2)	●	●
50 (2)	●	●
65 (2 1/2)	●	●
80 (3)	●	●
100 (4)	●	●
125 (5)	●	●
150 (6)	●	●
200 (8)	●	●
250 (10)	●	●
300 (12)	●	●

■ ELECTRIC BUTTERFLY VALVE TYPE N (P. II -8)

Power supply voltage	AC100V/200V	
Size \ Material	PVC	GF-PP
40 (1 1/2)	●	●
50 (2)	●	●
65 (2 1/2)	●	●
80 (3)	●	●
100 (4)	●	●
125 (5)	●	●
150 (6)	●	●
200 (8)	●	●
250 (10)	●	●
300 (12)	●	●

■ ELECTRIC BUTTERFLY VALVE TYPE KS (P. II -9)

Power supply voltage	AC100V/200V	
Size \ Material	PVC	GF-PP
40 (1 1/2)	●	●
50 (2)	●	●
65 (2 1/2)	●	●
80 (3)	●	●
100 (4)	●	●
125 (5)	●	●
150 (6)	●	●
200 (8)	●	●
250 (10)	●	●
300 (12)	●	●

SOLENOID VALVE

■ TYPE 121 (P. III -1)

Power supply voltage	AC100V/200V/DC24V	
Material	PVC	PVDF
Size	Thread	Thread
4	●	●
6	●	●

■ TYPE 131 (P. III -2)

Power supply voltage	AC100V/200V/DC24V					
Material	PVC			PVDF		
Size	Flange	Thread	TS	Flange	Thread	TS
13 (3/8)	—	●	●	—	●	●
15 (1/2)	●	●	●	●	●	●
20 (3/4)	●	●	●	●	●	●

■ TYPE 142 (P. III -3)

Power supply voltage	AC100V/200V/DC24V					
Material	PVC			PVDF		
Size	Flange	Thread	TS	Flange	Thread	TS
15 (1/2)	●	●	●	●	●	●
20 (3/4)	●	●	●	●	●	●
25 (1)	●	●	●	●	●	●
32 (1 1/4)	●	●	●	●	●	●
40 (1 1/2)	●	●	●	●	●	●
50 (2)	●	●	●	●	●	●

■ TYPE 6228 (P. III -4)

Power supply voltage	AC100V/200V/DC24V
Material	PPE/PA
Size	Thread
13A	●
15A	●

SENSOR

■ FLOW SENSOR TYPE 8030/TYPE 8035 (P.IV-1)

Material	PVC			PP	PVDF
	Flange	Thread	TS	Flange	Flange
15 (1/2)	●	●	●	●	●
20 (3/4)	●	●	●	●	●
25 (1)	●	●	●	●	●
32 (1 1/4)	●	●	●	●	●
40 (1 1/2)	●	●	●	●	●
50 (2)	●	●	●	●	●

■ FLOW SENSOR TYPE 8020/TYPE 8025 (P.IV-3)

Material	PVC	PP	PVDF
	Flange	Flange	Flange
65 (1/2)	●	●	●
80 (3)	●	●	●
100 (4)	●	●	●

■ FLOW SENSOR TYPE 8034 (P.IV-4)

Material	PVC			PP	PVDF
	Flange	Thread	TS	Flange	Flange
15 (1/2)	●	●	●	●	●
20 (3/4)	●	●	●	●	●
25 (1)	●	●	●	●	●
32 (1 1/4)	●	●	●	●	●
40 (1 1/2)	●	●	●	●	●
50 (2)	●	●	●	●	●

■ FLOW SENSOR TYPE 8031 (P.IV-5)

Material	ECTFE
Size	G 1/4

■ FLOW SENSOR TYPE 8045 (P.IV-6)

Material	PVC			PP	PVDF
	Flange	Thread	TS	Flange	Flange
15 (1/2)	●	●	●	●	●
20 (3/4)	●	●	●	●	●
25 (1)	●	●	●	●	●
32 (1 1/4)	●	●	●	●	●
40 (1 1/2)	●	●	●	●	●
50 (2)	●	●	●	●	●

■ pH SENSOR/ORP SENSOR/CONDUCTIVITY SENSOR (P.IV-7~9)

Material	PVC			PP	PVDF
	Flange	Thread	TS	Flange	Flange
15 (1/2)	●	●	●	●	●
20 (3/4)	●	●	●	●	●
25 (1)	●	●	●	●	●
32 (1 1/4)	●	●	●	●	●
40 (1 1/2)	●	●	●	●	●
50 (2)	●	●	●	●	●

Available size of Conductivity Sensor 32-50A

■ ULTRASONIC LEVEL SENSOR TYPE 8175 (P.IV-10)

Material	PVDF
Size	G2" Thread

Basic Notes

Please note the following items when you use or select the valve.

- The maximum working pressure described in each page is it at the room temperature 20°C. The maximum working pressure for an actual usable temperature have to refer to a diagram of page V-3.
- Please consider carefully use conditions of the temperature, pressure, density, etc. referring to "Chemical Resistance Manual for Eslon Plastic Pipes, Valves and Relative Materials", when you use or select the valve for the chemical application.
- The relating regulations might be applied to the equipment or facilities where the valve is used. Please confirm it in advance.
- The following products corresponds to the export restriction product according to regulations of Foreign Trade Control Law. The export admission of Japanese Government is needed when using it excluding Japan.
 - Valves which main body is made from PVDF
 - Butterfly valve with seat made from FPM

※1 The description of this catalog might change for the improvement of the product in future.

※2 The drawings and the part lists which were described in this catalog might be partially omitted. Please confirm them in the latest product approval drawing when the product is ordered and used. The latest information can confirm the homepage <http://www.eslon-plant.jp>.





I P n e u m a t i c V a l v e

- ESLON PNEUMATIC DIAPHRAGM VALVE TYPE B ----- I-1
- ESLON PNEUMATIC DIAPHRAGM VALVE TYPE D ----- I-2
- ESLON PNEUMATIC BALL VALVE TYPE C ----- I-3
- ESLON PNEUMATIC BUTTERFLY VALVE ----- I-4



ESLON PNEUMATIC DIAPHRAGM VALVE TYPE B



- Compact and light weight actuator
- High strength and excellent corrosion resistance
- Excellent durability, non-lubrication
- Available optional accessories on the actuator top on request.
- Easy handling and installation by flat flange bottom or fixing screw

● Flange Type [15A~50A]

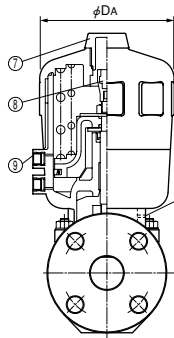
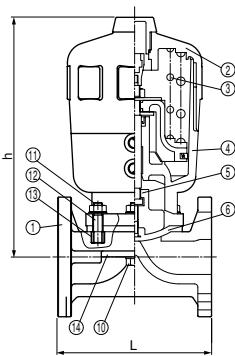

● Thread Type

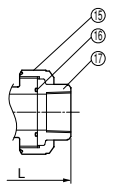

● TS Socket Type

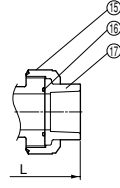

● Butt Type

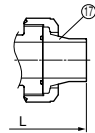

[65A~100A]

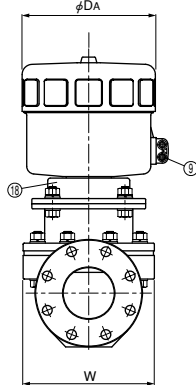
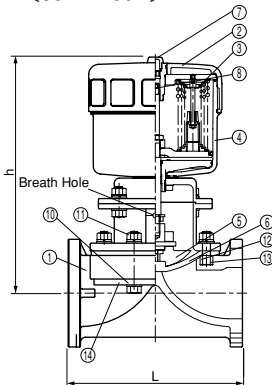

■ Parts List

No.	Part Name	Q'ty	Material
①	Body	1	PVC,HT,PP or PVDF
②	Cover	1	GF-PA
③	Spring	1	Spring Steel
④	Housing	1	GF-PA
⑤	Compressor	1	SCS14
⑥	Diaphragm	1	EPDM or PTFE
⑦	Indicator Cover	1	PC
⑧	Indicator	1	PA
⑨	Connection insert for air	2	SUS303
⑩	Bolt	—	SUS304
⑪	Nut	—	SUS304
⑫	Stud bolt for 40-100A	—	SUS304
⑬	Insert nut for 40-100A	—	C3604,SUS304(Only PVDF)
⑭	Supporting Plate for HT,PP or PVDF	1	50A or less: SUS304 65A or more: SS400 Painted by Epoxy Resin
⑮	Union Nut	2	PVC,HT,PP or PVDF
⑯	O-ring	2	EPDM or FPM
⑰	Socket	2	PVC,HT,PP or PVDF
⑱	Bonnet	—	AC-7

■ Option

Limit switch for open-close	Solenoid valve
Limit switch for open	Electro pneumatic positioner
Manual handle for open-close	Speed controller
Operating & Closing Control unit	Regulator with filter
Opening control unit	

■ Max. Operating Temperature

Material	Max. (°C)
PVC	50
HT	90
PP	90
PVDF	Thread, Butt 100 Flange 120

■ Standard Operating Air Pressure

Double Action	0.4MPa
Single Action	0.5MPa

■ Air Supply Port

Double Action	G 1/4
Single Action	G 1/4

Size		L				h		Da	Max. Working Pressure at Room Temp. (MPa)				Air Consumption (ℓ/time/unit)			Weight (kg/pc)	
A	B	Flange	Thread	TS Socket	Butt	Flange	Thread-TS Socket-Butt		Double Action		Single Action		Double Action	Positive Action	Reverse Action	Flange	Thread-TS Socket-Butt
									EPDM	PTFE	EPDM	PTFE					
15	1/2	110	133	144	185	169	167	101	0.7	0.5	0.7	0.5	0.36	0.25	0.11	1.5	1.5
20	3/4	120	158	172	200	172	167	101	0.7	0.5	0.7	0.5	0.40	0.28	0.12	1.5	1.5
25	1	130	181	187	212	171	174	101	0.5	0.3	0.6	0.4	0.41	0.28	0.14	1.7	1.7
32	1 1/4	180	—	262	—	281	284	158	0.5	0.3	0.6	0.4	1.09	0.62	0.47	6.0	6.0
40	1 1/2	180	248	262	273	281	284	158	0.5	0.3	0.6	0.4	1.09	0.62	0.47	6.0	6.0
50	2	210	280	298	300	286	289	158	0.4	0.2	0.6	0.4	1.23	0.67	0.56	6.9	6.9
65	2 1/2	250	—	—	—	435	—	211	0.4	0.2	0.6	0.4	3.49	0.92	0.93	12.5	—
80	3	280	—	—	—	436 (431)	—	211 (261)	0.4	0.2	0.6	0.4	3.98	1.18	1.42	14.3	—
100	4	340	—	—	—	465 (461)	—	211 (261)	0.4	0.2	0.5	0.3	3.34	1.00	1.45	24.0	—

• Parenthetical reference is the valve of reverse action
 • Size 32A is same as 40A, it is fabricated to long bolt hole φ19×21 of the flange

ESLON PNEUMATIC DIAPHRAGM VALVE TYPE D



- Epoxy resin coated aluminum actuator
- Light weight and excellent corrosion resistance
- Excellent durability, non-lubrication
- Available various optional accessories on the actuator top on request.
- Easy handling and installation by flat flange bottom or fixing screw

● Flange Type [Double Action]

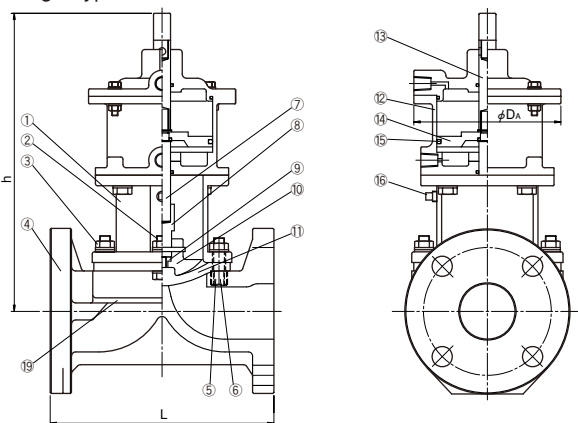

■ Parts List

No.	Part Name	Q'ty	Material	No.	Part Name	Q'ty	Material
①	Bonnet	1	AC-7	⑪	Diaphragm	1	EPDM or PTFE
②	Bolt	—	SUS304	⑫	Cylinder	1	AC-7
③	Nut	—	SUS304	⑬	Indicator	1	SUS304
④	Body	1	PVC, HT, PP or PVDF	⑭	Piston	1	AC-2
⑤	Stud Bolt	—	SUS304	⑮	O-ring	1	EPDM or FPM
⑥	Insert Nut	—	C3604, SUS304(PVDF)	⑯	Breath Plug	1	SUS304
⑦	Spindle	1	SUS304	⑰	Cylinder Ventilation Plug	1	C3601
⑧	Spindle Connector	1	SUS304	⑱	Spring	1	SUP10
⑨	Metallic Fixtures for Compressor	1	C3601	⑲	Supporting Plate for HT, PP or PVDF	1	50A or less SUS304 65A or more SS400 Painted by Epoxy Resin
⑩	Compressor	1	GF-PP				

● Flange Type [Single Action]

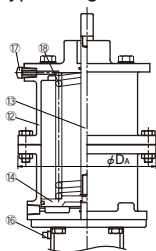

● Thread Type

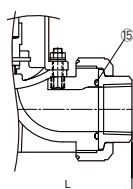

● TS Socket Type

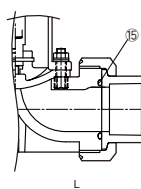

● Butt Fusion Type

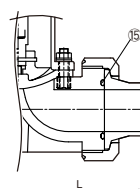

Unit:mm

Size		L				h		Da		Max. Working Pressure at Room Temp. (MPa)				Air Consumption (ℓ/time/unit)			Weight (kg/pc)	
A	B	Flange	Thread	TS Socket	Butt	Double Action	Single Action	Double Action	Single Action	Double Action		Single Action		Double Action	Positive Action	Reverse Action	Double Action	Single Action
										EPDM	PTFE	EPDM	PTFE					
15	1/2	110	133	144	185	157	254	116	138	0.7	0.5	0.7	0.5	0.29	0.17	0.31	2.0	4.2
20	3/4	120	158	172	200	174	270	116	138	0.7	0.5	0.7	0.5	0.29	0.19	0.33	2.1	4.3
25	1	130	181	187	212	187	283	116	138	0.5	0.3	0.6	0.4	0.29	0.21	0.35	2.5	4.7
32	1 1/4	180	—	262	—	249	366	138	180	0.5	0.3	0.6	0.4	0.66	0.33	0.82	4.0	8.5
40	1 1/2	180	248	262	273	249	366	138	180	0.5	0.3	0.6	0.4	0.66	0.33	0.82	4.0	8.5
50	2	210	280	298	300	280	397	138	180	0.4	0.2	0.6	0.4	0.66	0.43	0.92	5.2	9.7
65	2 1/2	250	—	—	—	355	463	180	230	0.4	0.2	0.6	0.4	1.39	0.90	1.40	8.8	16.5
80	3	280	—	—	—	405	598	232	312	0.4	0.2	0.6	0.4	2.55	2.50	3.70	14.2	35.8
100	4	340	—	—	—	523	659	260	312	0.4	0.2	0.5	0.3	4.90	3.00	4.20	23.7	44.4

*Size 32A is same as 40A, it is fabricated to long bolt hole φ19×21 of the flange

■ Option

Solenoid valve	Electro pneumatic positioner
Limit switch	Speed controller
Opening control unit	Regulator with filter
Pneumatic positioner	

Various optional accessories can be attached on request

■ Max. Operating Temperature

Material	Max. (°C)	
PVC	50	
HT	90	
PP	90	
PVDF	Thread, Butt	100
	Flange	120

■ Standard Operating Air Pressure

Double Action	0.4MPa
Single Action	0.5MPa

■ Air Supply Port

Double Action	Rc 1/4
Single Action	Rc 1/4

ESLON PNEUMATIC BALL VALVE TYPE C



- Double toggle-type of high powered aluminum actuator
- Light weight & compact actuator
- Excellent durability, non- lubrication
- Changeable into automatic/manual operation
- Available various optional accessories on the actuator top on request.

● Flange Type [Double Action]

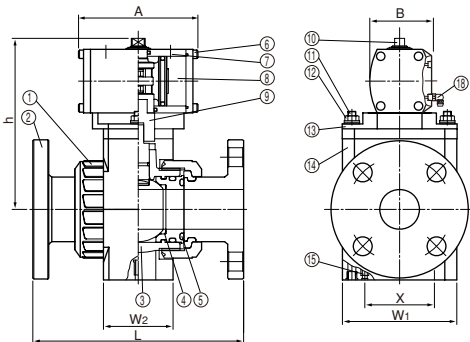

[Single Action]

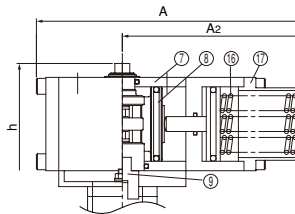

Parts List

No.	Part Name	Q'ty	Material
①	Union Nut	2	PVC,HT,PP or PVDF
②	Connections	2	PVC,HT,PP or PVDF
③	Body	1	PVC,HT,PP or PVDF
④	Ball Seat	2	PTFE
⑤	O-ring	2	EPDM,FPM or C-PE
⑥	Bolt	8	SUS304
⑦	Cylinder	1	A6063
⑧	Piston	2	AC2A
⑨	Connector	1	SUS304
⑩	Shaft	1	SCS13
⑪	Stud Bolt	2	SUS304
⑫	Nut	2	SUS304
⑬	Yoke	1	SS400 Painted by Epoxy Resin
⑭	Mount	1	FRP
⑮	Insert Nut	2	C3601
⑯	Spring	6	SWOSC-V
⑰	Spring Unit	1	A6063BE
⑱	Breath Plug	1	Cr Plated C3601

● Thread Type

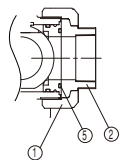

● TS Socket Type

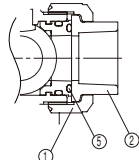

● Butt Type

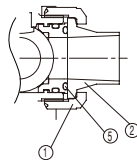

Unit:mm

Size	L		h		Actuator						W1	W2	X	Max. Working Pressure at Room Temp. (MPa)	Air Consumption (& time/unit)		Weight (kg/pc)			
					Double Action		Single Action		Double Action	Single Action					Double Action	Single Action				
	Flange	Thread	Double Action	Single Action	A	B	A	A2									B	Flange	Thread-TS	Flange
15	1/2	143 139	97 96	109 154	113 136	82 43	189 130	60 92	92 50	50 50	1.0	0.04	0.1	0.7	0.5	1.8	1.6			
20	3/4	172 168	116 115	132 162	120 139	82 43	189 130	60 92	92 50	50 50	1.0	0.04	0.1	0.8	0.6	1.9	1.7			
25	1	187 182	136 135	143 171	132 151	82 43	189 130	60 92	92 50	50 50	1.0	0.04	0.1	0.9	0.7	2.1	1.8			
32	1 1/4	190 185	149 146	166 177	156 156	120 64	189 130	60 98	98 60	55 50	1.0	0.16	0.1	1.9	1.3	2.4	1.9			
40	1 1/2	212 206	170 168	175 192	172 205	120 64	269 182	87 117	70 70	70 70	1.0	0.16	0.33	2.5	1.9	5.6	5.0			
50	2	234 228	197 195	203 203	179 208	120 64	269 182	87 135	70 70	85 70	1.0	0.16	0.33	3.2	2.3	6.3	5.4			
65	2 1/2	259 -	227 -	259 -	241 278	170 90	385 262	121 163	90 115	115 90	1.0	0.55	0.94	6.9	5.8	15.3	14.2			
80	3	304 -	278 -	304 -	306 306	243 121	385 262	121 198	110 140	140 110	1.0	0.55	0.94	12.9	12.0	17.3	16.4			
100	4	372 -	330 -	390 -	337 337	243 121	385 262	121 240	110 180	180 110	1.0	0.55	0.94	17.5	16.5	21.4	20.4			

Option

Solenoid valve	Speed controller
Limit switch	Regulator with filter
Pneumatic positioner	Opening control unit (Only Single actuation)
Electro pneumatic positioner	

Various optional accessories can be attached on request

Max. Operating Temperature

Material	Max. (°C)
PVC	50
HT	90
PP	80
PVDF	100

Standard Operating Air Pressure

Double Action	0.4MPa
Single Action	0.5MPa

Air supply port

Double Action	15~50A	Rc 1/8	65~100A	Rc 1/4
Single Action	15~32A	Rc 1/8	40~100A	Rc 1/4

ESLON PNEUMATIC BUTTERFLY VALVE



- ⊙ Double toggle-type of high powered aluminum actuator
- ⊙ Light weight, compact, and excellent corrosion resistance
- ⊙ Excellent durability, non-lubrication
- ⊙ Changeable into automatic/manual operation
- ⊙ Available various optional accessories by externally mounting
- ⊙ Speed controller and open-close adjuster standard equipment.

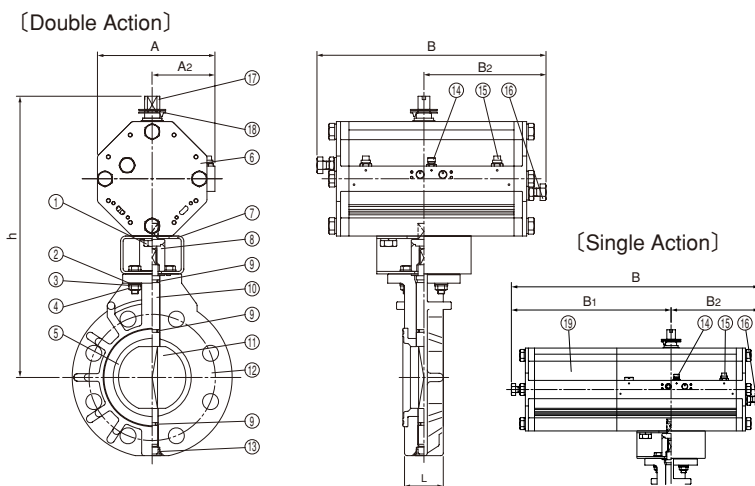

Parts List

No.	Part Name	Q'ty	Material
①	Bolt	2	SUS304
②	Washer	8	SUS304
③	Spring Washer	4	SUS304
④	Nut	4	SUS304
⑤	Seat Ring	1	EPDM or FPM
⑥	Cylinder	1	A6063/Alumite coating
⑦	Yoke	1	STKR
⑧	Connector	1	S45C
⑨	O-ring	1	EPDM or FPM
⑩	Stem	1	SUS420J2,SUS304 or SUS316
⑪	Disc	1	PP
⑫	Body	1	PVC or GF-PP
⑬	Cap	1	PP
⑭	Bypass Valve	1	—
⑮	Speed Controller	2	—
⑯	Adjustment screw	2	—
⑰	Opening indicator shaft	1	SCM
⑱	Indicator	1	—
⑲	Spring Unit	1	A6063 with Alumite coating

Double Action (40A~300A) ,Single Action (40A~200A)

Unit:mm

Size		L	h	Actuator								Max. Working Pressure at Room Temp. (MPa)	Air Consumption (ℓ/time/unit)			Weight (kg/pc)		
A	B			Double Action				Single Action					Double Action	Positive Action	Reverse Action	Double Action	Single Action	
A	B	L	h	A	A ₂	B	B ₂	A	A ₂	B	B ₁	B ₂	Double Action	Positive Action	Reverse Action	Double Action	Single Action	
40	1 1/2	33	273	105	55	191	104	105	55	267	180	104	1.0	0.56	0.20	0.36	4.2	5.2
50	2	43	280	105	55	191	104	105	55	267	180	104	1.0	0.56	0.20	0.36	4.4	5.4
65	2 1/2	46	291	105	55	191	104	105	55	267	180	104	1.0	0.56	0.20	0.36	4.7	5.7
80	3	46	334	140	75	272	145	140	75	407	280	145	1.0	1.46	0.52	0.94	7.0	11.8
100	4	52	354	140	75	272	145	188	99	462	301	181	1.0	1.46	1.18	2.16	8.0	20.0
125	5	56	442	188	95	342	181	188	99	462	301	181	1.0	3.34	1.18	2.16	14.5	21.5
150	6	60	451	188	95	342	181	188	99	685	481	258	1.0	3.34	3.17	2.48	15.4	31.7
200	8	71	503	188	95	342	181	188	99	685	481	258	1.0	3.34	3.17	2.48	18.5	35.5
250	10	76	571	188	95	462	258	—	—	—	—	—	1.0	5.65	—	—	31.1	—
300	12	114	601	188	95	462	258	—	—	—	—	—	1.0	5.65	—	—	38.2	—

Option

Solenoid valve	Pneumatic positioner
Limit switch	Electro pneumatic positioner
Manual operation unit(Only single action)	Regulator with filter
Opening control unit	

*Various optional accessories can be attached on request
Speed controller and opening adjuster are standard equipment.

Max. Operating Temperature

Material	Max. (°C)
PVC	50
GF-PP	80

Standard Operating Air Pressure

Double Action	0.4MPa
Single Action	0.5MPa

Air supply port

Double Action	Rc1/8
Single Action	Rc1/8



II Electric Valve

● ESLON ELECTRIC DIAPHRAGM VALVE TYPE KS	----- II-1
● ESLON ELECTRIC BALL VALVE TYPE K	----- II-2
● ESLON ELECTRIC BALL VALVE TYPE N	----- II-3
● ESLON ELECTRIC BALL VALVE TYPE KS	----- II-4
● ESLON ELECTRIC YP BALL VALVE	----- II-5
● ESLON ELECTRIC 3-WAY BALL VALVE	----- II-6
● ESLON ELECTRIC BUTTERFLY VALVE TYPE K	----- II-7
● ESLON ELECTRIC BUTTERFLY VALVE TYPE N	----- II-8
● ESLON ELECTRIC BUTTERFLY VALVE TYPE KS	----- II-9
● CONNECTING DIAGRAM	----- II-11



ESLON ELECTRIC DIAPHRAGM VALVE TYPE KS



- Epoxy resin coated aluminum actuator with compact motor
- Excellent durability & corrosion resistance
- Smooth flow control and water hammer relaxation by moderate action
- Visual position indicator equipped in front of actuator
- Manual open-close operation is available with enclosed box wrench

Parts List

No.	Part Name	Q'ty	Material
①	Cover	1	AC-4/Painted by Epoxy Resin
②	Actuator base	1	AC-3/Painted by Epoxy Resin
③	Bonnet	1	AC-7/Painted by Epoxy Resin
④	Bolt	—	SUS304
⑤	Nut	—	SUS304
⑥	Spring Pin	1	SUS304
⑦	Stud bolt	1	SUS304
⑧	Compressor	1	GF-PP
⑨	Diaphragm	1	EPDM or PTFE
⑩	Stud Bolt	—	SUS304
⑪	Body	1	PVC,HT,PP or PVDF
⑫	Indicator	1	—
⑬	Open-Close Plug	1	PP
⑭	Open-Close Stem	1	SUS304
⑮	Terminal Block	1	Phenol Resin
⑯	Conduit gland	1	G1/2
⑰	Supporting Plate	2	50A or less SUS304 65A or more SS400 Painted by Epoxy Resin
⑱	Union Nut	2	PVC,HT,PP or PVDF
⑲	O-ring	2	EPDM or FPM
⑳	Connections	2	PVC,HT,PP or PVDF

● Flange Type

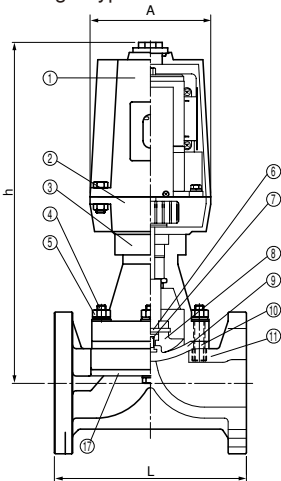

● Thread Type

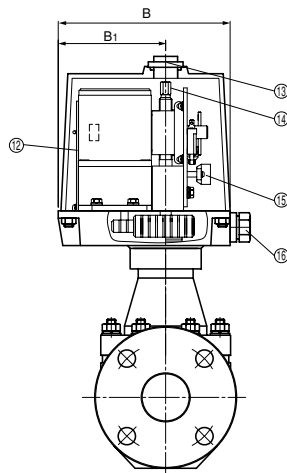

● TS Socket Type

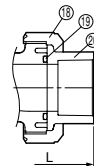

Size		L				h	Actuator			Max. Working Pressure at Room Temp. (MPa)		Time For Open-Close		Weight (kg/pc)
A	B	Flange	Thread	TS Socket	Butt		A	B	B1	EPDM	PTFE	50Hz	60Hz	
15	1/2	110	133	144	185	266	112	150	93	0.7	0.5	12	10	5.0
20	3/4	120	158	172	200	277	112	150	93	0.7	0.5	14	12	5.5
25	1	130	181	187	212	285	112	150	93	0.7	0.5	15	13	6.0
32	1 1/4	180	—	262	—	349	132	188	118	0.7	0.5	11	9	9.5
40	1 1/2	180	248	262	273	349	132	188	118	0.7	0.5	11	9	9.5
50	2	210	280	298	300	387	132	188	118	0.7	0.5	20	17	10.5
65	2 1/2	250	—	—	—	435	132	188	118	0.7	0.5	36	30	12.5
80	3	280	—	—	—	511	200	237	154	0.5	0.3	38	32	22.0
100	4	340	—	—	—	562	200	237	154	0.5	0.3	50	45	27.5
125	5	410	—	—	—	595	200	238	154	0.5	0.2	72	61	35.0
150	6	480	—	—	—	601	200	238	154	0.5	0.2	90	72	43.0

Unit:mm

*Size 32A is same as 40A, it is fabricated to long bolt hole $\phi 19 \times 21$ of the flange

Option

No-voltage limit switch	Potentiometer
Space heater	

Max. Operating Temperature

Material	Max. (°C)	
PVC	50	
HT	90	
PP	90	
PVDF	Thread, Butt	100
	Flange	120

Specification of Actuator

Nominal diameter (A)	15~25A	32~65A	80A	100A	125~150A
Input system	Power switching system				
Contact output	Power supply voltage				
Operating voltage	Single-phase AC100,200V (50/60Hz)				
Motor	Type	Reversible motor			
	Time rating	30 minutes rating			
Protect	Thermal protect inside				
	100V	0.3A	0.8A	1.0A	1.4A
200V	0.15A	0.4A	0.5A	0.7A	1.0A
Manual operation	Drive shaft direct operation				
Connector type	G1/2Conduit connector (max. $\phi 10.5$ Cabtire cable)				
Material	AC-4 Epoxy coating				
Protection	IP63				



ESLON ELECTRIC BALL VALVE TYPE K



- Aluminum die casting actuator
- Light weight, compact, and excellent corrosion resistance
- Visual position indicator equipped on top of actuator
- Smooth flow control and water hammer relaxation by moderate action
- Suitable for continuous operation
- Available manual open/close operation by handle
- CE compliance

● Flange Type

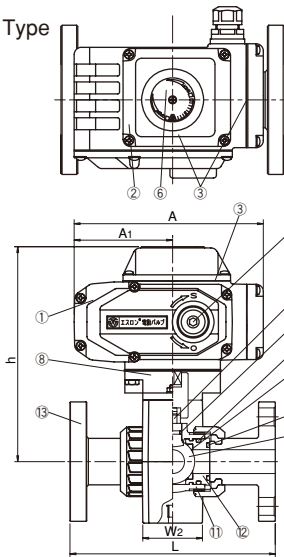

● Thread Type

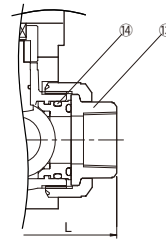

● TS Socket Type

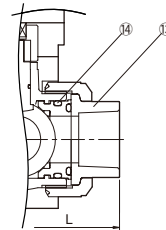

Parts List

No.	Part Name	Q'ty	Material
①	Actuator	1	ADC12
②	Screw	14	SUS304
③	Gasket	3	NBR
④	Rubber cap	1	NBR
⑤	Cable Gland	1	PA or ZDC/Fd
⑥	Indicator Cover	1	Toughened glass
⑦	Manual handle pivot	1	S45C
⑧	Yoke	1	AC4A
⑨	Stem	1	PVC,HT,PP or PVDF
⑩	Ball	1	PVC,HT,PP or PVDF
⑪	Valve Body	1	PVC,HT,PP or PVDF
⑫	Ball Stopper	2	PVC,HT,PP or PVDF
⑬	Connections	1	PVC,HT,PP or PVDF
⑭	O-ring	—	EPDM or FPM
⑮	Ball Seat	2	PTFE
⑯	Mount	1	FRP
⑰	Insert Nut	—	C3601

Unit:mm

Size		L						h	Actuator				W1	W2	X	Max. Working Pressure at Room Temp. (MPa)	Time For Open-Close		Weight (kg/pc)	
		Flange		Thread		TS Socket	Butt		A	A1	B	B2					50Hz	60Hz	Flange	Thread+TS Socket
A	B	PVC-HT	PP-PVDF	PVC	PVDF	PVC-HT	PVDF													
15	1/2	143	139	97	96	109	154	178	158.5	82.5	141.5	78	92	50	50	1.0	4	3.3	3.5	3.3
20	3/4	172	168	116	115	132	162	180	158.5	82.5	141.5	78	92	50	50	1.0	4	3.3	3.8	3.4
25	1	187	182	136	135	143	171	193	158.5	82.5	141.5	78	92	50	50	1.0	4	3.3	4.2	3.6
32	1 1/4	190	185	149	146	166	177	197	158.5	82.5	141.5	78	98	60	55	1.0	15	12.5	4.7	4.0
40	1 1/2	212	206	170	168	175	192	204	158.5	82.5	141.5	78	117	70	70	1.0	15	12.5	5.5	4.9
50	2	234	228	197	195	203	206	211	158.5	82.5	141.5	78	135	70	85	1.0	15	12.5	6.5	5.5
65	2 1/2	259	—	227	—	259	—	239	158.5	82.5	141.5	78	163	90	115	1.0	15	12.5	8.5	7.3
80	3	304	—	278	—	304	—	295	206.5	97.5	147.5	80.5	198	110	140	1.0	30	25	14.9	13.8
100	4	372	—	330	—	390	—	325	206.5	97.5	147.5	80.5	240	110	180	1.0	30	25	20.8	19.8

Option

No-voltage limit switch	Potentiometer
Space heater	

Max. Operating Temperature

Material	Max. (°C)
PVC	50
HT	90
PP	80
PVDF	100

Specification of Actuator

Nominal diameter (A)	15~65A	80~100A	
Input system	Power switching system		
Contact output	Power supply valve		
Operating voltage	Single-phase AC100/110,200/220V (50/60Hz)		
Motor	Type	Reversible motor	
	Time rating	Continuous rating	
Protect	Thermal protect inside Adjustable mechanical stopper for open and close-side		
Resistance	100/110V	0.7/0.9A	0.65/0.70A
	200/220V	0.4/0.5A	0.35/0.40A
Manual operation	Drive shaft direct operation		
Connector type	G1/2 Conduit (Cable OD φ9-11)		
Material	ADC12 Epoxy coating		
Protection	IP66		



ESLON ELECTRIC BALL VALVE TYPE N



- Aluminum die casting actuator
- Light weight, compact, and excellent corrosion resistance
- Available 2 type of motors, standard type and high speed type of open-close control
- Visual indicator for open/close position is equipped in the actuator
- Available manual open/close operation

● Flange Type

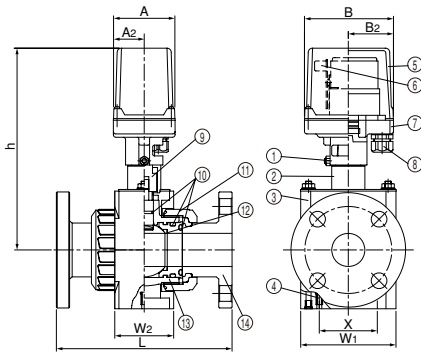

● Thread Type

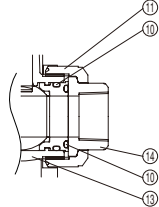

● TS Socket Type

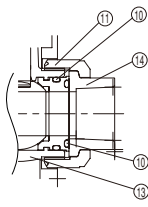

Parts List

No.	Part Name	Q'ty	Material
①	Screw	1	SUS304
②	Yoke	1	SUS304
③	Mount	1	FRP
④	Insert Nut	2	C3603
⑤	Actuator Cover	1	PC
⑥	Terminal block	1	—
⑦	Actuator base	1	ADC-12
⑧	Cable connector	1	PA
⑨	Connector	1	C3604
⑩	O-ring	1	EPDM, FPM or C-PE
⑪	Union Nut	2	PVC, HT, PP or PVDF
⑫	Ball Seat	2	PTFE
⑬	Body	1	PVC, HT, PP or PVDF
⑭	Connections	2	PVC, HT, PP or PVDF

Standard Type (15~40A), Higher Speed Type (15~100A)

Size		L						h		Actuator				W1	W2	X	Max. Working Pressure at Room Temp. (MPa)	Time For Open-Close				Weight (kg)		
A	B	Flange		Thread		TS Socket		Butt	Standard Type	Higher Speed Type	A	A2	B					B2	Standard Type	Higher Speed Type	Standard Type	Higher Speed Type	Flange	Thread-TS Socket
		PVC-HT	PP-PVDF	PVC	PVDF	PVC-HT	PVDF										50Hz	60Hz	50Hz	60Hz				
15	1/2	143	139	97	96	109	154	166	166	193	74	37	107	71	92	50	50	1.0	5.4	4.5	3	2.5	2.0	1.7
20	3/4	172	168	116	115	132	162	168	168	195	74	37	107	71	92	50	50	1.0	15.5	13	3	2.5	2.2	1.8
25	1	187	182	136	135	143	171	181	181	208	74	37	107	71	92	50	50	1.0	15.5	13	3	2.5	2.5	2.0
32	1 1/4	190	185	149	146	166	177	228	228	228	74	37	107	54	98	60	55	1.0	16	13.5	6	5	3.3	2.7
40	1 1/2	212	206	170	168	175	192	244	244	244	74	37	107	54	117	70	70	1.0	16	13.5	6	5	3.9	3.4
50	2	234	228	197	195	203	206	—	—	331	160	93	175	105	135	70	85	1.0	—	—	3~4	—	11.0	10.0
65	2 1/2	259	—	227	—	259	—	—	—	351	160	93	175	105	163	90	115	1.0	—	—	3~4	—	14.0	13.0
80	3	304	—	278	—	304	—	—	—	377	160	93	175	105	198	110	140	1.0	—	—	6~10	—	18.0	17.0
100	4	372	—	330	—	390	—	—	—	412	160	93	175	105	240	110	180	1.0	—	—	6~10	—	24.5	24.0

Option

No-voltage limit switch

Max. Operating Temperature

Material	Max. (°C)
PVC	50
HT	90
PP	80
PVDF	100

Specification of Actuator

Type	Standard Type	Higher Speed Type
Nominal diameter (A)	15~32A	40A
Input system	15~40A	50~100A
Contact output	Power switching system	
Operating voltage	Power supply voltage	
Motor	Single-Phase AC100/110,200/220V (50/60Hz)	
Type	Inductor type synchronous motor	
Time rating	15 minutes rating under loading rate 20%	
Protect	Thermal protect inside	Thermal protect inside Thermistor type
Power consumption	16VA	19VA 50VA 100VA max.
Manual operation	Release of the screw lock	Drive shaft direct operation
Connector type	G3/8 wire connector (φ5~φ10.5Cable cable)	
Material	ADC acrylic resin baking finish	
Protection	IP65	
Other	Space Heater	



ESLON ELECTRIC BALL VALVE TYPE KS



- Epoxy resin coated aluminum actuator
- Excellent durability & corrosion resistance
- High open/close speed
- Visual indicator for open/close position is equipped in the actuator
- Available manual open/close operation by wrench

Parts List

No.	Part Name	Q'ty	Material
①	Cover	1	AC-4/ Painted by Epoxy Resin
②	Bolt	4	SUS304
③	Cover Gasket	1	NR
④	Nut	4	SUS304
⑤	Actuator base	1	AC-7/ Painted by Epoxy Resin
⑥	Union Nut	2	PVC,HT,PP or PVDF
⑦	Connections	2	PVC,HT,PP or PVDF
⑧	Driver stem	1	SUS303
⑨	O-ring	1	EPDM,FPM or C-PE
⑩	Body	1	PVC,HT,PP or PVDF
⑪	Ball Seat	2	PTFE
⑫	Manual operation system	1	SUS303
⑬	Terminal Block	1	Phenol Resin
⑭	Insert Nut	1	C3603
⑮	Conduit gland	1	G1/2
⑯	Stud Bolt	2	SUS304
⑰	Nut	2	SUS304
⑱	Mount	1	FRP

● Flange Type (15~40A)

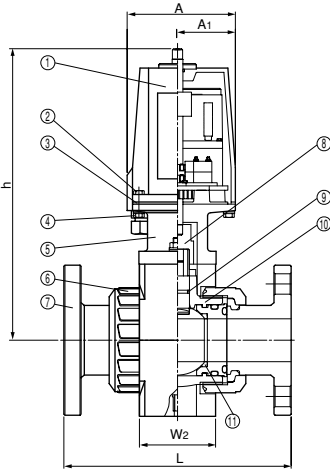

(50~100A)

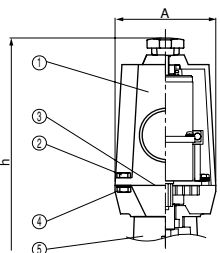

● Thread Type

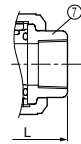

● TS Socket Type

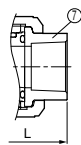

● Butt Type

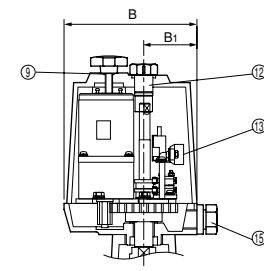
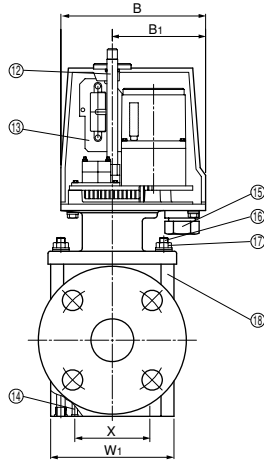
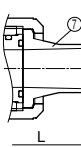

Option

No-voltage limit switch	Potentiometer
Space Heater	

Specification of Actuator

Nominal diameter (A)	15~40A	50~65A	80~100A	
Input system	Power switching system			
Contact output	Power supply voltage			
Operating voltage	Single-phase AC100,200V (50/60Hz)			
Motor	Type	Reversible motor		
	Time rating	30 minutes rating		
Protect	Thermal protect inside			
Resistance	100V	0.2	0.3	0.6
	200V	0.15	0.15	0.3
Manual operation	Drive shaft direct operation			
Connector type	G1/2 wire connector (max.φ10.5 Cabtire cable)			
Material	AC-4 Epoxy coating			
Protection	IP63			

Max. Operating Temperature

Material	Max. (°C)
PVC	50
HT	90
PP	80
PVDF	100

Unit:mm

Size	A		L						h	Actuator				W1		W2	X	Max. Working Pressure at Room Temp. (MPa)	Time For Open-Close		Weight (kg/pc)	
	Flange	Butt	PVC	PVDF	TS Socket	Butt	A	A1		B	B1	Flange	Thread-TS Socket	50Hz	60Hz				Flange	Thread-TS Socket		
15	1/2	143	139	97	96	109	154	229	102	54	136	88	92	92	50	50	1.0	4	3	3.3	3.0	
20	3/4	172	168	116	115	132	162	232	102	54	136	88	92	92	50	50	1.0	4	3	3.5	3.1	
25	1	187	182	136	135	143	171	246	102	54	136	88	92	92	50	50	1.0	4	3	3.8	3.3	
32	1 1/4	190	185	149	146	166	177	252	102	54	136	88	97	98	60	55	1.0	7	6	4.0	3.4	
40	1 1/2	212	206	170	168	175	192	271	102	54	136	88	120	117	70	70	1.0	7	6	4.7	4.1	
50	2	234	228	197	195	203	206	329	110	55	145	58	135	135	70	85	1.0	7	6	7.7	6.8	
65	2 1/2	259	—	227	—	259	—	339	110	55	145	58	166	163	90	115	1.0	7	6	9.8	8.6	
80	3	304	—	278	—	304	—	425	130	65	180	88	192	198	110	140	1.0	7	6	15.7	14.7	
100	4	372	—	330	—	390	—	455	130	65	180	88	236	240	110	180	1.0	7	6	21.6	21.0	

ESLON ELECTRIC YP BALL VALVE



- Easy flow rate control with the particular flow channel geometry
- Self open/close control with 4- 20mA signal input
- Epoxy resin coated Aluminum actuator
- Visual indicator for open/close position is equipped in the actuator

● Flange Type

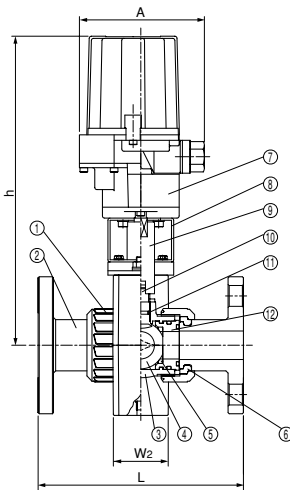

● Thread Type

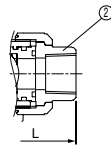

● TS Socket Type

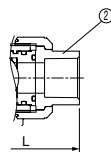

■ Parts List

No.	Part Name	Q'ty	Material
①	Union Nut	2	PVC
②	Connections	2	PVC
③	Body	1	PVC
④	Ball	1	PVC
⑤	Ball Seat	2	PTFE
⑥	Set Ring	2	PVC
⑦	Electric Actuator	1	—
⑧	Yoke	1	SUS304
⑨	Joint	1	SUS303
⑩	Stem	1	PVC
⑪	O-ring	1	EPDM,FPM or C-PE
⑫	Ball Stopper	2	PVC
⑬	Stud Bolt	2	SUS304
⑭	Nut	2	SUS304
⑮	Spring Washer	2	SUS304
⑯	Washer	2	SUS304
⑰	Yoke	1	FRP
⑱	Mount	1	FRP
⑲	Insert Nut	2	C3601

Unit:mm

Size		L			h	Actuator		W1	W2	X	Du	Max. Working Pressure at Room Temp. (MPa)	Time For Open-Close	Weight (kg/pc)	
A	B	Flange	Thread	TS Socket		A	B							Flange	Thread-TS Socket
15	1/2	143	97	109	267	114	98	93	53	50	49	1.0	10	3.5	3.1
20	3/4	172	116	132	270	114	98	93	53	50	59	1.0	10	4.0	3.5
25	1	187	136	143	282	114	98	93	53	50	67	1.0	10	4.5	4.0
32	1 1/4	190	149	166	286	114	98	98	61	55	81	1.0	10	5.0	4.5
40	1 1/2	212	170	175	336	174	110	117	70	70	98	1.0	13	6.0	5.5
50	2	234	197	203	343	174	110	135	70	85	120	1.0	13	7.0	6.4

■ Max. Operating Temperature

Material	Max. (°C)
PVC	50

■ Specification of Actuator

Nominal diameter (A)	15~32A	40~50A
Operating voltage	DC24V	
Power consumption	14.4W	
Motor type	Synchronous motor	
Protective function	・Overload (lock) protection function ・Re-starting limit timer	
Opening detection	Potentiometer	
Input signal	DC4-20mA (Input resistance250Ω)	
Output signal	DC1~5V (Allowable load resistance 5kΩ or more)	
Resolution	1/1000	
Manual operation	None.	Drive shaft operation
Connector type	G1/2 female screw with 1m-cable	
Material	ADC	
Protection class	IP55	

ESLON ELECTRIC 3-WAY BALL VALVE



- Controllable open/close position and flow rate in 3-way
- Aluminum die casting actuator
- Light weight, compact, and Excellent corrosion resistance
- Visual indicator for open/close position is equipped in the actuator
- Available manual open/close operation

● Flange Type

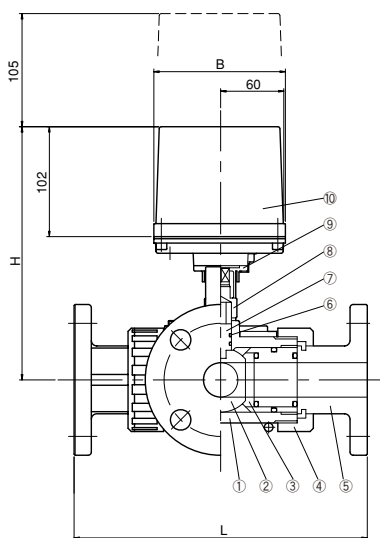

● Thread Type

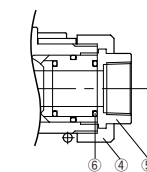
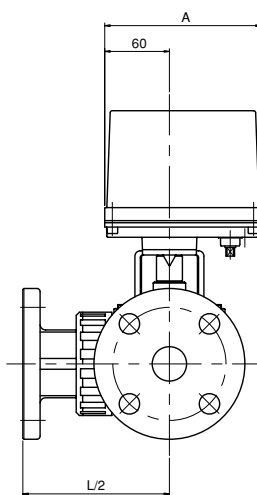

● TS Socket Type

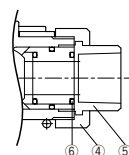

■ Parts List

No.	Part Name	Q'ty	Material
①	Body	1	PVC
②	Ball	1	PVC
③	Ball Stopper		PVC
④	Union Nut		PVC
⑤	Connections		PVC
⑥	O-ring	11	EPDM or FPM
⑦	Stem	2	PVC
⑧	Connector	1	C3604BD
⑨	Bracket	1	SCS13
⑩	Electric Actuator	1	—

Unit:mm

Size		L			h	Actuator		Max. Working Pressure at Room Temp. (MPa)	Time For Open-Close		Weight (kg/pc)	
A	B	Flange	Thread	TS Socket		A	B		50Hz	60Hz	Flange	Thread-TS Socket
15	1/2	163	118	129	202	145	122	1.0	9.5	8	3.7	3.2
20	3/4	200	134	151	206	145	122	1.0	9.5	8	3.9	3.4
25	1	221	156	175	221	145	122	1.0	9.5	8	4.5	3.6
40	1 1/2	272	203	232	235	145	122	1.0	7.6	6	5.8	4.9
50	2	306	225	260	246	145	122	1.0	7.6	6	7.3	5.7

■ Option

No-voltage limit switch

■ Max. Operating Temperature

Material	Max. (°C)
PVC	50

■ Specification of Actuator

Nominal diameter (A)	15~25A	32~65A
Input system	Power switching system	
Contact output	Power supply voltage	
Operating voltage	Single-phase AC100/110,200/220V (50/60Hz)	
Motor	Type	Synchronous motor Reversible motor
	Time rating	15 minutes rating under loading rate 20%
Protect	Thermal protect inside	
Power consumption	19VA	60VA
Manual operation	Drive shaft direct operation	
Connector type	G1/2 conduit (Cable connector) (Φ6-12 calibre cable)	
Material	ADC acrylic resin baking finish	
Protection	IP65	
Other	Space Heater	

ESLON ELECTRIC BUTTERFLY VALVE TYPE K



- Aluminum die casting actuator and Integrated bonnet with motor
Light weight, Compact, and Excellent corrosion resistance
- Visual position indicator equipped on the top of actuator.
- Smooth flow control and water hammer relaxation by moderate action.
- Suitable for continuous operation
- Available manual open/close operation by handle
- CE compliance

● Flange Type

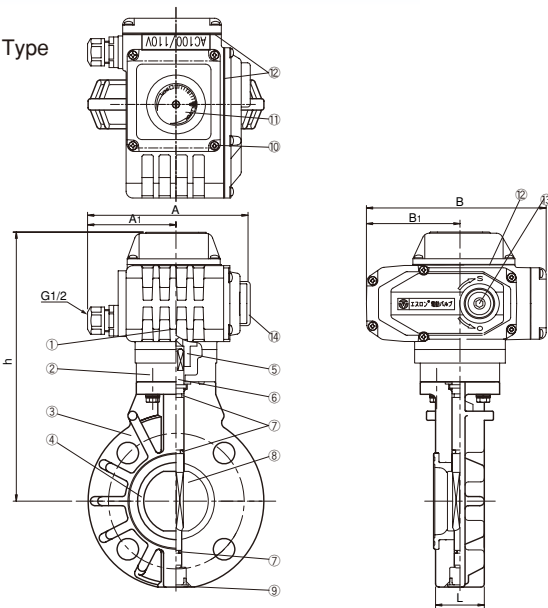

Parts List

No.	Part Name	Q'ty	Material
①	Electric Actuator	1	ADC12/Epoxy Baking Finish
②	Yoke	1	AC4A
③	Body	1	PVC or GF-PP
④	Seat Ring	1	EPDM or FPM
⑤	Connector	1	ZDC2
⑥	Stem	1	SUS420J2 or SUS316
⑦	O-ring	3	EPDM or FPM
⑧	Disc	1	PP
⑨	Cap	1	PP
⑩	Screw	14	SUS304
⑪	Open-Close Indicator	1	Toughened glass
⑫	Gasket	3	NBR
⑬	Manual Handle Pivot	1	S45C
⑭	Rubber cap	1	NBR

Unit:mm

Size		L	h	Actuator				Max. Working Pressure at Room Temp. (MPa)	Time For Open-Close		Weight (kg/pc)
A	B			A	A ₁	B	B ₁		50Hz	60Hz	
40	1 1/2	33	230	141.5	63.5	158.5	85.5	1.0	15	12.5	3.3
50	2	43	237	141.5	63.5	158.5	82.5	1.0	15	12.5	3.5
65	2 1/2	46	248	141.5	63.5	158.5	82.5	1.0	15	12.5	3.8
80	3	46	282	147.5	67	206.5	97.5	1.0	30	25	6.1
100	4	52	302	147.5	67	206.5	97.5	1.0	30	25	6.9
125	5	56	348	182.5	94	256.5	123	1.0	30	25	11.8
150	6	60	357	182.5	94	256.5	123	1.0	30	25	12.8
200	8	71	409	182.5	94	256.5	123	1.0	30	25	15.1
250	10	76	486	242	137	381	181.5	1.0	30	25	33.0
300	12	114	516	242	137	381	181.5	1.0	30	25	40.1

Option

No-voltage limit switch	Potentiometer
Space heater	

Max. Operating Temperature

Material	Max. (°C)
PVC	50
GF-PP	80

Specification of Actuator

Nominal diameter (A)	40~65A	80~100A	125~200A	250~300A	
Input system	Power switching system				
Contact output	Power supply voltage				
Operating voltage	Single-phase AC100/110,200/220V (50/60Hz)				
Motor	Type	Reversible motor			
	Time rating	Continuous rating			
Protect	Thermal protect inside				
	Adjustable mechanical stopper for open-side and close-side				
Rated current	100/110V	0.7/0.9A	0.65/0.70A	1.1/1.2A	1.8/2.0A
	200/220V	0.4/0.5A	0.35/0.40A	0.55/0.60A	0.9/1.0A
Manual operation	with manual operation mechanism				
Connector type	G1/2 conduit (Cable ODΦ9~11)				
Material	ADC12 Epoxy coating				
Protection class	IP66				

ESLON ELECTRIC BUTTERFLY VALVE TYPE N



- ⊙ Aluminum die casting actuator
- ⊙ Light weight, compact, and excellent corrosion resistance
- ⊙ Available 2 types of open/close speed, high speed with smaller diameter and slow speed with bigger diameter
- ⊙ Easy flow rate control & water hammer relaxation.
- ⊙ Visual indicator for open/close position is equipped in the actuator
- ⊙ Available manual open/close operation

[40A~200A]

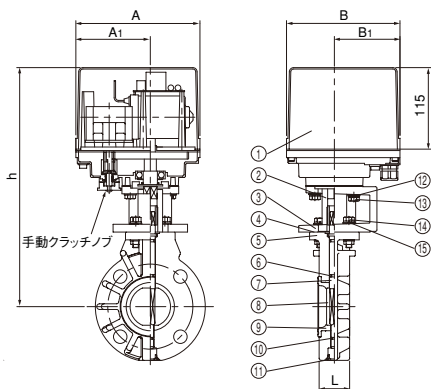

[250・300A]

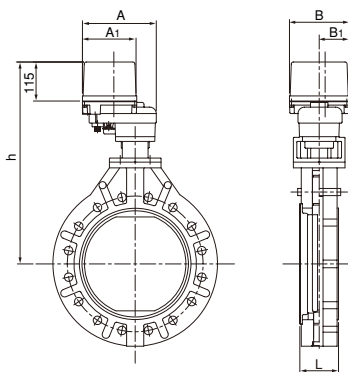

Parts List

No.	Part Name	Q'ty	Material
①	Actuator	1	—
②	Connector	1	S45C/Electroless Ni Deposition
③	Yoke	1	ADC12
④	Adaptor Plate	1	SUS304
⑤	Disc	1	PVC or GF-PP
⑥	O-ring	2	EPDM or FPM
⑦	Stem	1	SUS420J2 or SUS316
⑧	Gate	1	PP
⑨	Seat Ring	1	EPDM or FPM
⑩	O-ring	1	EPDM or FPM
⑪	Cap	1	PP
⑫	Washer	4	SUS304
⑬	Bolt	4	SUS304
⑭	Bolt	4	SUS304
⑮	Washer	4	SUS304

Unit:mm

Size		L	h	Actuator				Max. Working Pressure at Room Temp. (MPa)	Time For Open-Close (50/60Hz)	Weight (kg/pc)
A	B			A	A1	B	B1			
40	1 1/2	33	330	175	105	160	92.5	1.0	3~4	7.8
50	2	43	338	175	105	160	92.5	1.0	3~4	8.0
65	2 1/2	46	348	175	105	160	92.5	1.0	3~4	8.5
80	3	46	356	175	105	160	92.5	1.0	6~10	9.0
100	4	52	388	175	105	160	92.5	1.0	6~10	10.5
125	5	56	425	175	105	160	92.5	1.0	8~15	14.0
150	6	60	434	175	105	160	92.5	1.0	8~15	15.0
200	8	71	485	175	105	160	92.5	1.0	8~15	18.0
250	10	76	565	217.5	158	175	87.5	1.0	24~45	27.0
300	12	114	595	217.5	158	175	87.5	1.0	24~45	34.0

Option

No-voltage limit switch	Potentiometer
-------------------------	---------------

Max. Operating Temperature

Material	Max. (°C)
PVC	50
GF-PP	80

Specification of Actuator

Nominal diameter (A)	40~100A	125~200A	250-300A
Input system	Power switching system		
Contact output	Power supply voltage		
Operating Voltage	Single-phase AC100/110,200/220V (50/60Hz)		
Motor	Type	DC Motor	
	Time rating	15 minutes rating under loading rate 20%	
Protect	Thermistor type		
Power consumption	100VA max.	150VA max.	120VA max.
Manual operation	Drive shaft direct operation		Drive shaft manipulation
Connector type	G1/2 wire connector(φ6-12 Cabtire cable)		
Material	ADC acrylic resin baking finish		
Protection	IP65		
Other	Space heater		



ESLON ELECTRIC BUTTERFLY VALVE TYPE KS



- ⊙ Epoxy resin coated aluminum actuator
- ⊙ High open/close speed
- ⊙ Visual indicator for open/close position is equipped in the actuator
- ⊙ Available manual open/close operation by wrench

(40~200A)

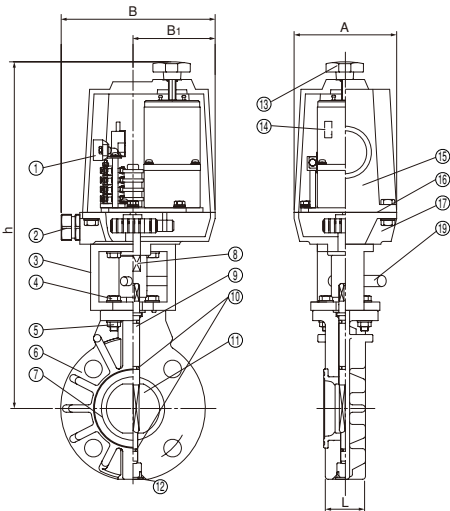

(250~300A)

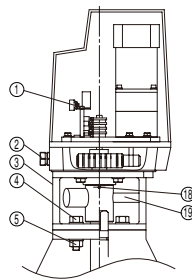

Parts List

No.	Part Name	Q'ty	Material
①	Terminal Block	1	Phenol Resin
②	Conduit gland	1	G1/2
③	Yoke	1	AC-7/Epoxy Resin
④	Bolt	4	SUS304
⑤	Nut	4	SUS304
⑥	Disc	1	PVC or GF-PP
⑦	Seat Ring	1	EPDM or FPM
⑧	Driver stem	1	SUS303/Epoxy Resin
⑨	Stem	1	SUS420J2 or SUS316
⑩	O-ring	2	EPDM or FPM
⑪	Gate	1	PP
⑫	Cap	1	PP
⑬	M/A switching screw	1	Epoxy Resin
⑭	Thermal protector	1	—
⑮	Cover	1	AC-4/Epoxy Resin
⑯	Cover Gasket	1	CR
⑰	Actuator base	1	AC-3/Epoxy Resin
⑱	M/A switching pin	1	SUS304 (250A or more)
⑲	Manual operation handle	1	SUS304

Specification of Actuator

Nominal diameter (A)	40~65A	80~100A	125~200A	250~300A	
Input system	Power switching system				
Contact output	Power supply voltage (Operating voltage)				
Operating voltage	Single-phase AC100/200V 50/60Hz				
Motor	Type	Reversible motor			
	Time rating	30 minutes rating			
Protect Thermal protect inside					
Rated current	100V	0.3	0.6	1.0	1.8
	200V	0.15	0.3	0.5	0.9
Manual operation	Drive shaft direct operation				
Connector type	G1/2 wire connector (max. φ10.5 Cabtire cable)				
Material	AC-4 Epoxy coating				
Protection	IP63				

Unit:mm

Size		L	h	Actuator			Max. Working Pressure at Room Temp. (MPa)	Time For Open-Close		Weight (kg/pc)
A	B			A	B	B1		50Hz	60Hz	
40	1 1/2	33	365	110	165	88	1.0	7.2	6	4.8
50	2	43	372	110	165	88	1.0	7.2	6	5.1
65	2 1/2	46	383	110	165	88	1.0	7.2	6	5.4
80	3	46	433	130	200	110	1.0	7.2	6	8.1
100	4	52	452	130	200	110	1.0	7.2	6	9.0
125	5	56	541	168	259	152	1.0	7.2	6	16.6
150	6	60	550	168	259	152	1.0	7.2	6	17.6
200	8	71	602	168	259	152	1.0	7.2	6	19.0
250	10	76	718	227	281	153	1.0	18.0	15	28.6
300	12	114	749	227	281	153	1.0	18.0	15	35.6

Option

No-voltage limit switch	Potentiometer
Space Heater	

Max. Operating Temperature

Material	Max. (°C)
PVC	50
GF-PP	80



Connecting diagram

The following is the connecting diagram of the standard type.
It is different in the case of the option type.

■ ELECTRIC DIAPHRAGM VALVE TYPE KS, ELECTRIC BALL VALVE TYPE KS, ELECTRIC BUTTERFLY VALVE TYPE KS

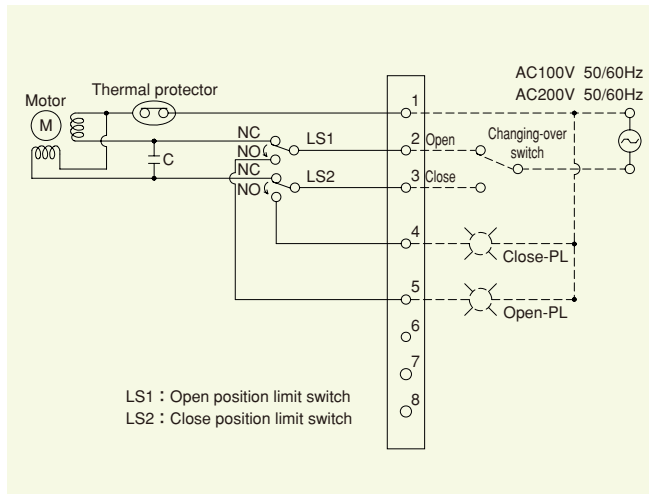

- Terminal1 : Power source common terminal
- 2 : Power terminal for opening
- 3 : Signal terminal for closing
- 4 : Signal terminal for opening
- 5 : Signal terminal for closing
- 6 : be not in use
- 7 : be not in use
- 8 : be not in use

Precaution

- ⚠ Please don't distribute current to open and close in parallel
- ⚠ Please install selector switch for each valve because operation of multiple valve by one selector switch cause mechanical error

■ ELECTRIC BALL VALVE TYPE K, ELECTRIC BUTTERFLY VALVE TYPE K

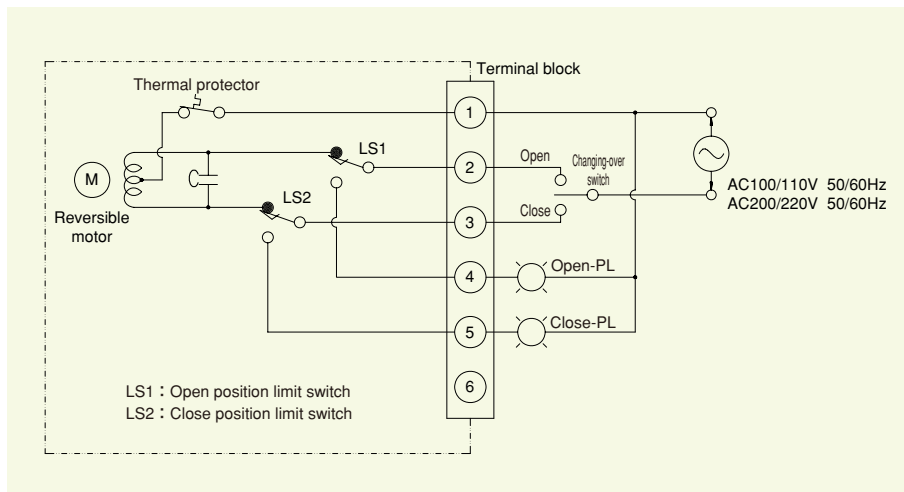

- Terminal1 : Power source common terminal
- 2 : Power terminal for opening
- 3 : Signal terminal for closing
- 4 : Signal terminal for opening
- 5 : Signal terminal for closing
- 6 : be not in use

Precaution

- ⚠ Please don't distribute current to open and close in parallel
- ⚠ Please install selector switch for each valve because operation of multiple valve by one selector switch cause mechanical error

■ ELECTRIC BALL VALVE TYPE N STANDARD TYPE, 3-WAY BALL VALVE

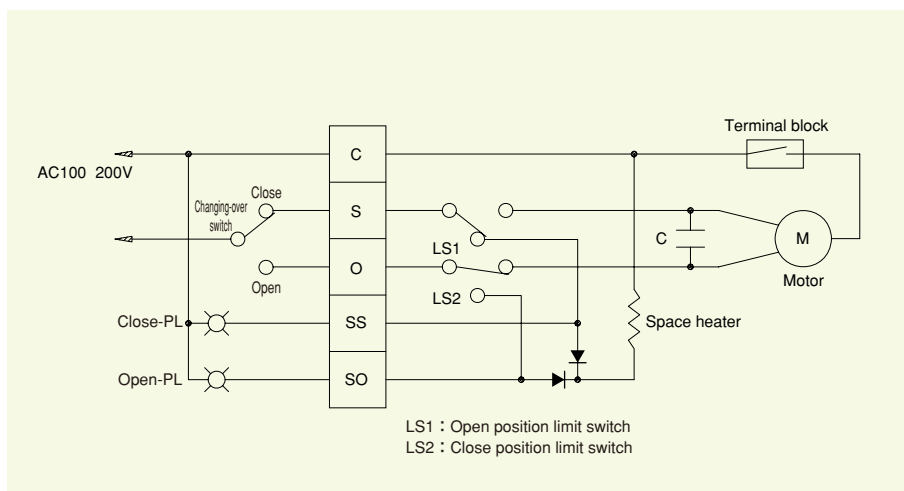

- TerminalC : Power source common terminal
- S : Terminal for closing
- O : Terminal for opening
- SS : Signal terminal for closing
- SO : Signal terminal for opening

Precaution

- ⚠ Please don't distribute current to open and close in parallel
- ⚠ Please install selector switch for each valve because operation of multiple valve by one selector switch cause mechanical error

ELECTRIC BALL VALVE TYPE N HIGHER SPEED TYPE (15~40A)

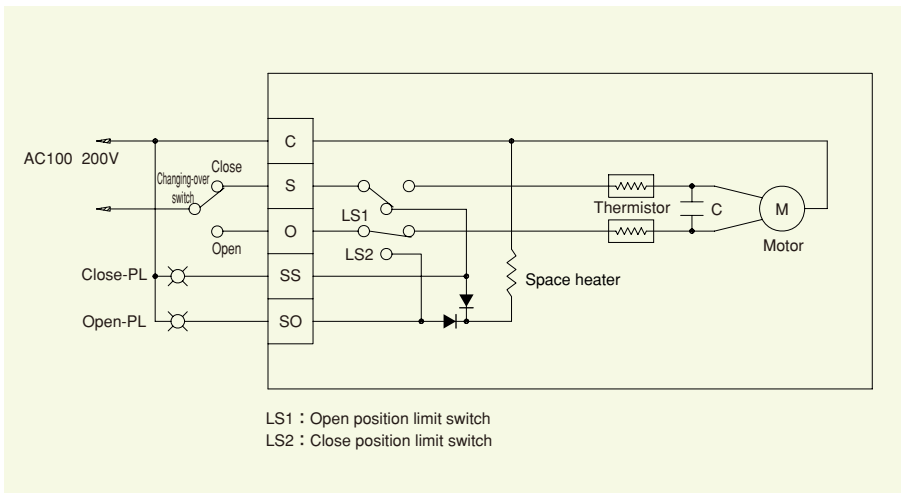

Terminal C : Power source common terminal
S : Terminal for closing
O : Terminal for opening
SS : Signal terminal for closing
SO : Signal terminal for opening

Precaution

- ⚠ Please don't distribute current to open and close in parallel
- ⚠ Please install selector switch for each valve because operation of multiple valve by one selector switch cause mechanical error

ELECTRIC BALL VALVE TYPE N HIGHER SPEED TYPE (50~100A), ELECTRIC BUTTERFLY VALVE TYPE N

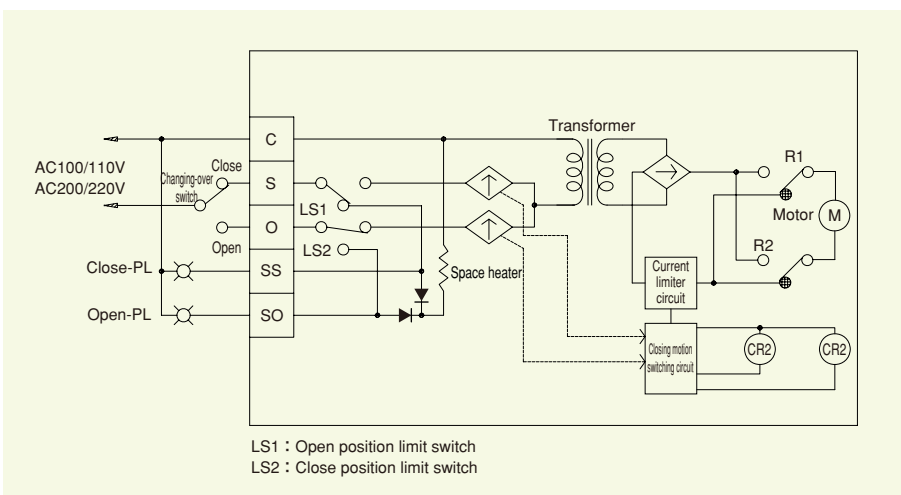

Terminal C : Power source common terminal
S : Terminal for closing
O : Terminal for opening
SS : Signal terminal for closing
SO : Signal terminal for opening

Precaution

- ⚠ Please don't distribute current to open and close in parallel
- ⚠ Please install selector switch for each valve because operation of multiple valve by one selector switch cause mechanical error

ELECTRIC YP BALL VALVE

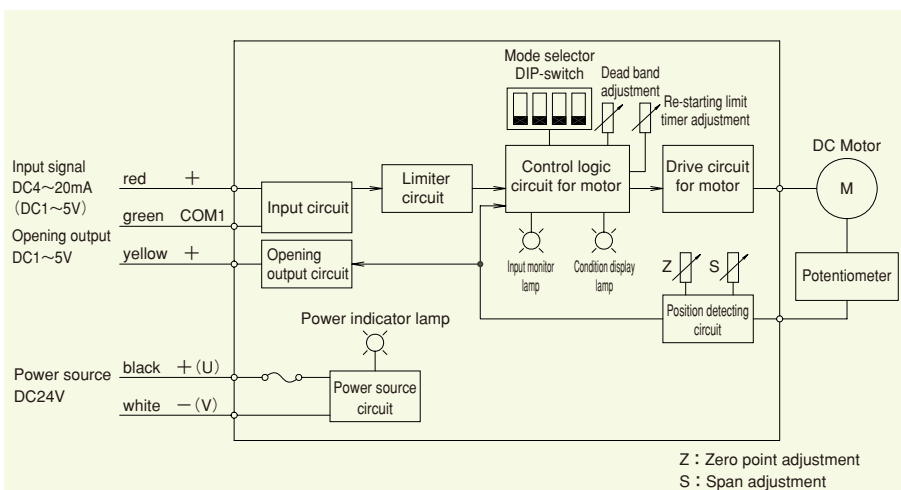



III Solenoid Valve

- SOLENOID VALVE TYPE 121 ----- III-1
- SOLENOID VALVE TYPE 131 ----- III-2
- SOLENOID VALVE TYPE 142 ----- III-3
- SOLENOID VALVE TYPE 6228 ----- III-4

ESLON SOLENOID VALVE TYPE 121



- Excellent sealing & durability flapper type solenoid valve
- Suitable for small diameter pipe or tube
- Excellent sealing & durability flapper type of valve
- Excellent chemical resistance because epoxy coated coil is isolated from flow channel by double diaphragms
- Suitable for long term operation

● Thread Type

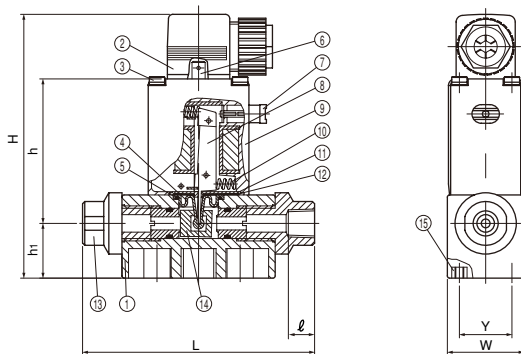

■ Parts List

No.	Part Name	Q'ty	Material
①	Body	1	PVC or PVDF
②	Cable plug	1	PA
③	Slotted screw	4	SUS316
④	Toggle pin	1	PTFE
⑤	O-ring	3	EPDM or FPM
⑥	Terminal	-	-
⑦	Manual operation push button	1	PA
⑧	Flapper	1	SS400+Ni Plated
⑨	Solenoid	1	-
⑩	Spring	1	SUS304CSP
⑪	Gasket	1	EPDM or FPM
⑫	Isolating diaphragm	1	SUS316
⑬	Reducing fitting	2	PVC or PVDF
⑭	Seal	3	EPDM or FPM
⑮	Insert Nut	4	SUS316

Unit:mm

Orifice d	L		R	ℓ	φD	H	h ₁	h	W	Y	Cv	Operating Press. Range (MPa)	Time For Open-Close (msec)	Weight (kg/pc)
	PVC	PVDF												
4	101	106	R1/4	12	20	120	25	66	35	24	0.35	0~0.2	15~25	0.32
6	101	106	R1/4	12	20	120	25	66	35	24	0.70	0~0.1	15~25	0.32

■ Specification

Type	Type121
Operating voltage	DC24V, AC100~110V, AC200~240V
Power Consumption	DC24V 8.5W (inrush / hold) AC100/200V 40VA (inrush) ,18VA/7W (hold)
Coil insulation class	Class F
Rated time	Continuance
Protection class	IP65

■ Max. Operating Temperature

Material	Max. (°C)
PVC	50
PVDF	70

ESLON SOLENOID VALVE TYPE 131



- Excellent sealing & durability flapper type solenoid valve
- Excellent chemical resistance because epoxy coated coil is isolated from flow channel by double diaphragms
- Suitable for long term operation

● Flange Type

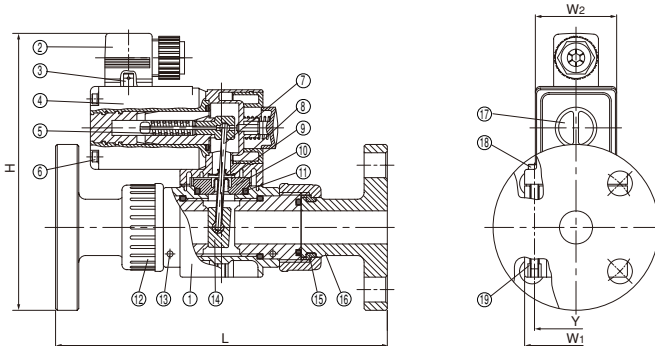

● Thread Type

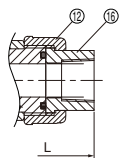

● TS Socket Type

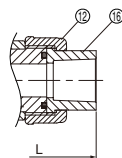

■ Parts List

No.	Part Name	Q'ty	Material
①	Body	1	PVC or PVDF
②	Cable plug	1	PA
③	Terminal	—	—
④	Solenoid	1	—
⑤	Spring	1	SUS304CSP
⑥	Slotted screw	4	SUS316
⑦	Flapper	1	SS400+Ni Plated
⑧	Gasket	1	FPM
⑨	Collar	1	SUS316
⑩	Pendulum part	1	PTFE
⑪	O-ring	6	EPDM or FPM
⑫	Union Nut	2	PVC or PVDF
⑬	Set Pin	2	SUS316
⑭	Seal	1	EPDM or FPM
⑮	Set Ring	2	PVDF
⑯	Pipe connection	2	PVC or PVDF
⑰	Manual operation push button	1	PA
⑱	Slotted screw	2	SUS316
⑲	Insert Nut	2	SUS316

Unit:mm

Size		L			H		W1	W2	Y	Cv	Operating Press. Range (MPa)	Time For Open-Close (msec)		Weight (kg/pc)
A	B	Flange	Thread	TS Socket	Flange	Thread+TS Socket						Close-Open	Open-Close	
13	3/8	—	138	138	—	147	62	49	50	2.3	0.3	10~20	40~60	1.2
15	1/2	202	148	149	165	147	62	49	50	5.3	0.1	10~20	40~60	1.2
20	3/4	204	158	160	167	147	62	49	50	7.0	0.05	10~20	40~60	1.2

■ Specification

Type	Type131
Operating voltage	DC24V, AC100~110V, AC200~240V
Power Consumption	DC24V 100W (inrush), 9W (hold) AC100/200V 100-120VA (inrush), 32VA/16W (hold)
Coil insulation class	Class F
Rated time	Continuance
Protection class	IP65

■ Max. Operating Temperature

Material	Max. (°C)
PVC	50
PVDF	70

ESLON SOLENOID VALVE TYPE 142



- Pilot operation type solenoid with diaphragm valve
- Small pressure loss
- Maximum operating pressure : 0.6MPa

Parts List

No.	Part Name	Q'ty	Material
①	Body	1	PVC or PVDF
②	Manual operation push button	1	PA
③	Spring	1	SUS304CSP
④	Body	1	PTFE
⑤	Disc	1	PVDF
⑥	Diaphragm	1	EPDM or FPM
⑦	Restrictor	1	PVDF
⑧	Terminal	—	—
⑨	Solenoid	1	—
⑩	Flapper	1	SS400+Ni Plated
⑪	Gasket	1	EPDM or FPM
⑫	Orifice plug	2	PVDF
⑬	O-ring	8	EPDM or FPM
⑭	Socket	2	PVC or PVDF
⑮	Union Nut	2	PVC or PVDF
⑯	DIN Connector	1	PA
⑰	Slotted screw	4	SUS316
⑱	Bolt	4	SUS316
⑲	Washer	4	SUS316
⑳	Insert Nut	4	SUS316
㉑	Insert Nut	2	SUS316

● Flange Type

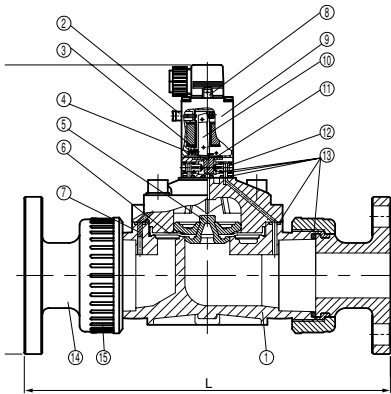

● Thread Type

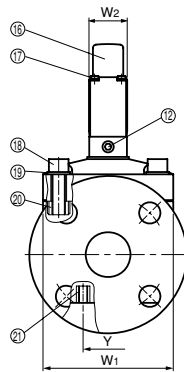

● TS Socket Type

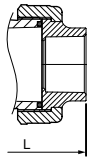

Unit:mm

Size		L		H		W1	W2	Y	Cv	Operating Press. Range (MPa)	Time For Open-Close (sec)		Weight (kg/pc)
A	B	Flange	Thread·TS Socket	Flange	Thread·TS Socket						Close-Open	Open-Close	
15	1/2	215	162	201	177	62.5	34	40	5.8	0.05~0.6	0.1~0.8	1~6	0.7
20	3/4	215	170	203	177	62.5	34	40	7.0	0.05~0.6	0.1~0.8	1~6	0.7
25	1	262	208	230	203	44.5	34	44.5	16.4	0.05~0.6	0.1~0.8	1~6	1.2
32	1 1/4	259	211	235	203	44.5	34	44.5	18.8	0.05~0.6	0.1~0.8	1~6	1.2
40	1 1/2	326	268	261	237	44.5	34	44.5	35.2	0.05~0.6	0.1~0.8	1~6	2.2
50	2	334	276	269	237	44.5	34	44.5	45.2	0.05~0.6	0.1~0.8	1~6	2.2

Specification

Type	Type142	
Operating voltage	DC24V, AC100~110V, AC200~240V	
Power	DC24V	5W (inrush / hold)
Consumption	AC100/200V	20VA (inrush), 11VA/5W (hold)
Coil insulation class	Class F	
Rated time	Continuance	
Protection class	IP65	

Max. Operating Temperature

Material	Max. (°C)
PVC	50
PVDF	70

ESLON SOLENOID VALVE TYPE 6228



- Pilot operation type solenoid valve with diaphragm
- Small pressure loss
- Maximum operating pressure : 1.0MPa
- Application of type 6228 for portable water

● 13A
(AC100/200V)

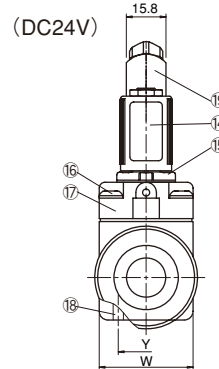
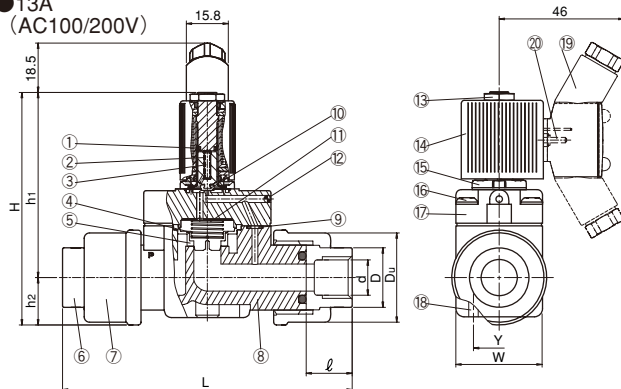

(DC24V)

● 15A
(AC100/200V)

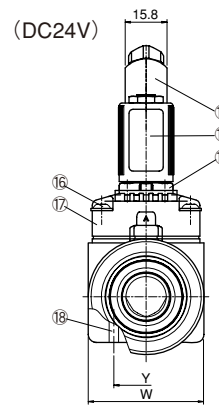
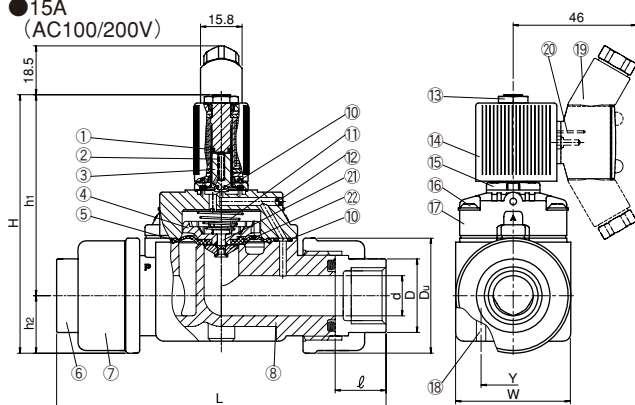

(DC24V)

Parts List

No.	Part Name	Q'ty	Material
①	S Coil	1	Cu
②	Spring	1	SUS301
③	Plunger	1	SUS430F
④	Disc	1	PPS—GF
⑤	Diaphragm	1	NBR
⑥	Thread Socket	2	PPE/PA
⑦	Union Nut	2	PPE/PA
⑧	Body	1	PPE/PA
⑨	O-ring	2	EPDM or FPM
⑩	Pilot valve	1	EPDM or FPM
⑪	Spring	1	SUS301
⑫	Sealing ball	1	Stainless steel
⑬	Lock Nut	1	SUM (Zn Plated)
⑭	Coil	1	PA
⑮	Flange	1	C.Steel (Zu Plated)
⑯	Thread	4	Stainless steel
⑰	Cover	1	PPE/PA
⑱	Hole for the mounting	2	—
⑲	DIN Connector	1	PA
⑳	Terminal	—	brass (Ag Plated)
㉑	Boit	1	SUS316
㉒	Diaphragm holder	1	brass

Unit:mm

Size		d	L	Socket With Tread			Du	H	h1	h2	W	Y	Cv	Operating Range (MPa)	Time For Open-Close (msec)		Weight (kg/pc)
A	B			Nominal Size Of Female Thread	ℓ	D							Close-Open		Open-Close		
13	3/8	10	107	Rc3/8	17	22.0	32	86.0	68.5	17.5	32	19	2.1	0.05~1.0	30	150	0.13
15	1/2	15	123	Rc1/2	19	27.5	43	96.5	75.0	21.5	43	24	3.7	0.05~1.0	60	300	0.18

Max. Operating Temperature

Material	Max. (°C)
PPE/PA	50

Specification

Type	Type 6228
Operating voltage	DC24V, AC100~110V, AC200~240V
Power Consumption	DC24V 4W (inrush / hold)
	AC100/200V 9VA (inrush), 6VA (hold)
Coil insulation class	Class F
Rated time	Continuance
Protection class	IP65



IV Sensor

■ FLOW SENSOR ■

- FLOW SENSOR Type 8030/Type 8035 ----- IV-1
- FLOW SENSOR Type 8020/Type 8025 ----- IV-3
- FLOW SENSOR Type 8034 ----- IV-4
- FLOW SENSOR Type 8031 ----- IV-5
- FLOW SENSOR Type 8045 ----- IV-6

■ ANALYSIS SENSOR ■

- PH SENSOR Type 8205 ----- IV-7
- ORP SENSOR Type 8206 ----- IV-8
- CONDUCTIVITY SENSOR Type 8225 ----- IV-9

■ ULTRASONIC LEVEL SENSOR ■

- ULTRASONIC LEVEL SENSOR Type 8175 ----- IV-10

■ Notes of Sensor ■

- Notes of Sensor ----- IV-11

ESLON FLOW SENSOR TYPE 8030 (Pulsed Output) TYPE 8035 (Digital Output)



- PVDF 4 paddles type digital flow meter
- Easy maintenance by isolated transmitter from flow channel
- Unsuitable for slurry or crystallizable fluid

● Flange Type [Type8030]

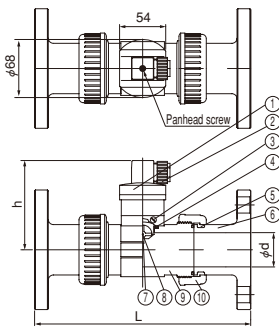

[Type8030 with output module]

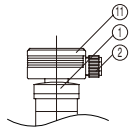

[Type8035]

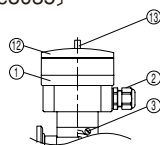

● Thread Type

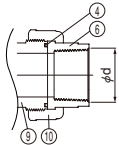

● TS Socket Type

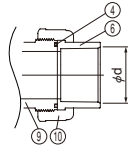

● Butt Type

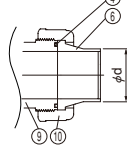

■ Parts List

No.	Part Name	Q'ty	Material
①	transmitter	1	PC
②	Cable gland	1	PA
③	Screw	1	SUS304
④	O-ring	3	EPDM or FPM
⑤	Set Ring	2	PVDF
⑥	Socket	2	PVC,PP or PVDF
⑦	Paddle	1	PVDF
⑧	Axis and bearing	1	Ceramic
⑨	Body	1	PVC,PP or PVDF
⑩	Union Nut	1	PVC,PP or PVDF
⑪	Output module	1	PA
⑫	Transmitter cover	1	PC
⑬	Cover screw	1	SUS304

Unit:mm

Size		φd		L		h			Weight (kg/pc)					
									Type8030			Type8035		
		Flange	Thread·TS Socket·Butt	Flange	Thread·TS Socket·Butt	Normal	With Module	Type8035	Normal		With Module		Flange	Thread·TS Socket·Butt
15	1/2	15	15	192	141	99	114	141	0.6	0.3	0.5	0.3	0.8	0.5
20	3/4	20	21	202	160	96	111	138	0.7	0.4	0.6	0.3	0.9	0.6
25	1	26	26	228	178	97	112	139	0.9	0.4	0.9	0.4	1.1	0.6
32	1 1/4	32	33	228	180	100	115	142	1.2	0.6	1.1	0.5	1.4	0.8
40	1 1/2	40	40	254	196	105	120	105	1.3	0.7	1.3	0.7	1.6	0.9
50	2	50	50	271	214	111	126	111	2.0	1.1	2.0	1.1	2.3	1.3

■ Max. Operating Temperature & Max. Operating Pressure

Material	Max. (°C)	Max. (MPa) at room temp.
PVC	50	1.0
PP	80	
PVDF	100	

Specification

Type8030

Measuring range	0.3~10m/s (0.5~10m/s for coil detection type) 15A:approx. 3~ 100 ℓ/min 20A:approx. 5~ 190 ℓ/min 25A:approx. 8~ 300 ℓ/min 32A:approx.12~ 420 ℓ/min 40A:approx.19~ 720 ℓ/min 50A:approx.32~1180 ℓ/min	
Accuracy	Teach-In:±0.5%FS ^{※1} Standard K-factor:±(±0.5%FS ^{※1} +2.5%RD ^{※2})	
Repeatability	0.4%RD ^{※2}	
Linearity	±0.5%FS ^{※1}	
Protection class	IP65 ^{※3}	
Ambient temperature	-15~60°C	
Relative humidity	< 80% non condensated	
Hall element type	Operating voltage	DC12~30V
	Current consumption	30mA (non-load)
	Pulse output signal	Open-collector PNP/NPN,max100mA,Frequency 0~200Hz
Output module 4-20mA output module type	Operating voltage	DC12~24V
	Output signal	DC4~20mA Load 500Ω (12V) 1000Ω (24V)
	Accuracy	< 2%
	Operating voltage	DC12~30V
Calibrated pulse output module type	Output signal	Open-collector PNP/NPN,max100mA
	Accuracy	0.1%

Under reference conditions i.e. measuring fluid=water, ambient and water temperature=20°C, applying the minimum inlet and outlet pipe straights, matched inside pipe dimensions.

※1.FS:Full scale (10m/s)

※2.RD:Reading of indication value

※3.The back of the panel type controller is IP20

Panel type controller, Box type controller

Measuring range	0.3~10m/s (0.5~10m/s for coil detection type) 15A:approx. 3~ 100 ℓ/min 20A:approx. 5~ 190 ℓ/min 25A:approx. 8~ 300 ℓ/min 32A:approx.12~ 420 ℓ/min 40A:approx.19~ 720 ℓ/min 50A:approx.32~1180 ℓ/min	
Accuracy	Teach-In:±0.5%FS ^{※1} Standard K-factor:±(±0.5%FS ^{※1} +2.5%RD ^{※2})	
Repeatability	0.4%RD ^{※2}	
Linearity	±0.5%FS ^{※1}	
Protection class	IP65 ^{※3}	
Ambient temperature	-15~60°C	
Relative humidity	< 80% non condensated	
Standard type	Operating voltage	DC12~30V
	Current consumption	20mA (Standard type,Reed relay/Opt.) 80mA (with Relay output)
	Output signal	4-20mA output DC4~20mA Load 900Ω (30V) 500Ω (24V) 100Ω (15V)
Output signal	Calibrated pulse output	Open-collector PNP/NPN,max100mA (Reed relay/Opt.) Switching rate:max. 10 pulse/sec Load:below 34V, < 0.2A
	Relay output	230V/3A X 2contact
Battery type	Operating voltage	Dry battery(square type) X 2pcs
	Battery life	with the alkaline battery, approx. 1-2 years
Batch controller type	Operating voltage	DC12~30V
	Output signal (Relay output)	230V/3A X 2contact

Under reference conditions i.e. measuring fluid=water, ambient and water temperature=20°C, applying the minimum inlet and outlet pipe straights, matched inside pipe dimensions.

※1.FS:Full scale (10m/s)

※2.RD:Reading of indication value

※3.The back of the panel type controller is IP20.

Function table (Type8030/Type8035)

	Type	Display		4-20 mA	pulse	Calibrated pulse		Relay output	Batch function	Detection method	
		Moment	Integrating			Open-collector	Reed relay				
Type 8030	Standard				●					Hall element type	
		Output module			●※3						LP-hall element type
	Panel type	Calibrated pulse					●				LP-hall element type
		Standard	●	●	●※3		●				LP-hall element type
		Standard reed relay/Opt.	●	●	●			●			LP-hall element type
		with Relay output	●	●	●		●		●	●	LP-hall element type
		Batch controller type	※2	●							LP-hall element type
	BOX type	Standard	●	●	●※3		●				LP-hall element type
		Standard reed relay/Opt.	●	●	●			●			LP-hall element type
		with Relay output	●	●	●		●		●		LP-hall element type
		Battery type	●	●						●	Coil type
		Batch controller type	※2	●							LP-hall element type
Type 8035	Standard	●	●	●※3		●				Coil type	
	Standard reed relay/Opt.	●	●	●			●			Coil type	
	with Relay output	●	●	●		●		●		Coil type	
	Battery type	●	●							Coil type	
	Batch controller type	※2	●						●	Coil type	

4-20mA : The 4-20mA signal which is in proportion to the moment flow is outputted.

Pulse : 1-pulse is outputted in every 1/2-cycle of the paddle.

Calibrated pulse : 1-pulse is outputted in every setup unit flow.

Relay output : The contact signal of ON/OFF is outputted by the optional setup moment flow.

Batch function : It is the control function of the valve in the combination with the automatic valve.

※1. Only when the operating unit was loaded.

※2. It is displayed for two seconds by the switching operation of the display.

※3. 2-wire type

ESLON FLOW SENSOR TYPE 8020 (Pulsed Output) TYPE 8025 (Digital Output)

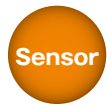

- PVDF 4 paddles type digital flow meter
- Available wide range of pressure applications, 0.02 - 1.0 MPa
- Unsuitable for slurry or crystallizable fluid

● Type8020

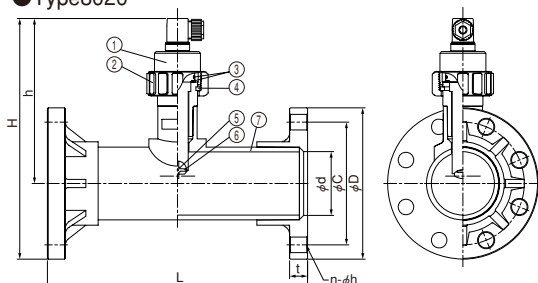

● Type8020 with output module

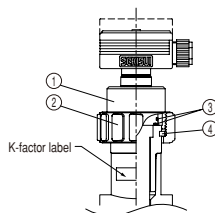

● Type8025

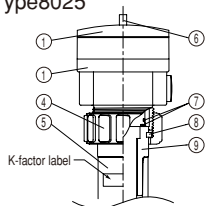

■ Parts List

No.	Part Name	Q'ty	Material
①	Transmitter	1	—
②	Union Nut	1	PA
③	O-ring	1	EPDM or FPM
④	Set Ring	1	PVDF
⑤	Axis and bearing	1	Seramic
⑥	Paddle	1	PVDF
⑦	Fitting	1	PVC

Size		φd	L	Flange Socket				H	h
A	B			φD	φC	n-φh	t		
65	1/2	67	310±2.0	175	140	4-19	22	283	195
80	3	78	320±2.0	185	150	8-19	22	294	202
100	4	100	530±2.0	210	175	8-19	22	303	198

Flange dimension is JIS-B222:2004 conformity.

■ Specification

Type8020

Measuring range	0.3~10m/s(0.5~10m/s for coil detection type) 65A:approx. 60~2000 ℓ/min 80A:approx. 90~3000 ℓ/min 100A:approx.150~4800 ℓ/min
Accuracy	Teach-In:±0.5%FS ^{※1} Standard K-factor:±(±0.5%FS ^{※1} +2.5%RD ^{※2})
Repeatability	0.4%RD ^{※2}
Linearity	±0.5%FS ^{※1}
Protection class	IP65 ^{※3}
Ambient temperature	-15~60°C
Relative humidity	< 80% (non condensing)
Hall element type	Operating voltage DC12~30V Pulse output signal Open-collectorPNP/NPN,max100mA
output type	Operating voltage DC12~24V Output signal 4-20mA Load 500Ω (12V) 1000Ω (24V) Accuracy within 2%
pulse output type	Operating voltage DC12~30V Output signal Open-collectorPNP/NPN,max100mA Accuracy 0.1%

Type8025, Panel type controller, Box type controller

Measuring range	0.3~10m/s(0.5~10m/s for coil detection type) 65A:approx. 60~2000 ℓ/min 80A:approx. 90~3000 ℓ/min 100A:approx.150~4800 ℓ/min
Accuracy	Teach-In:±0.5%FS ^{※1} Standard K-factor:±(±0.5%FS ^{※1} +2.5%RD ^{※2})
Repeatability	0.4%RD ^{※2}
Linearity	±0.5%FS ^{※1}
Protection class	IP65 ^{※3}
Ambient temperature	-15~60°C
Relative humidity	< 80% (non condensing)
Standard	Operating voltage DC12~30V Current consumption 20mA (Standard,optRestrictor) 80mA (with Relay output) DC4-20mA output Load 900Ω (30V) 500Ω (24V) 100Ω (15V)
	Calibrated pulse output Open-collectorPNP/NPN,max100mA Relay output 230V/3A X 2contact [※] with Relay output only
^{※4} Battery type	Operating voltage Dry battery(square type) X 2pcs Battery life with the alkaline battery, approx. 1-2 years

■ Max. Operating Temperature & Max. Operating Pressure

Material	Max. (°C)	Max. (MPa) at room temp.
PVC	50	0.6
PP	80	
PVDF	100	

■ Function table (Type8020/Type8025)

Type	Type	Display		4-20 mA	Pulse	Calibrated pulse	Relay output	Detection method	
		Moment	Integrating						
Type 8020	Hall element type				●			Hall element type	
	4-20mA output	※1		●※2				LP-hall element type	
	Pulse output type					●		Hall element type	
	option combination	Panel type	Standard	●	●	●※2	●		Hall element type
		Box type	with Relay output	●	●	●	●	●	Hall element type
			Battery type	●	●	●	●	●	●
Type 8025	Standard	●	●	●	●※2	●		Hall element type	
	with Relay output	●	●	●	●	●	●	Hall element type	
	Battery type	●	●					Coil type	

Pulse : 1-pulse is outputted in every 1/2-cycle of the paddle.

Calibrated pulse : 1-pulse is outputted in every setup unit flow.

Relay output : The contact signal of ON/OFF is outputted by the optional setup moment flow.

※1. Only when the operating unit was loaded.

※2. 2-wire type

Under reference conditions i.e. measuring fluid=water, ambient and water temperature=20°C, applying the minimum inlet and outlet pipe straights, matched inside pipe dimensions.

※1.FS:Full scale (10m/s)

※2.RD:Reading of indication value

※3.The back of the panel type controller is IP20.

※4.type8020/Box-model controller only.

ESLON FLOW SENSOR TYPE 8034 (Analog Display)



Mounted Type

- ◎ PVDF 4 paddles type analog flow meter
- ◎ Selectable full-scale on the meter, corresponding to flow rate

● Flange Type

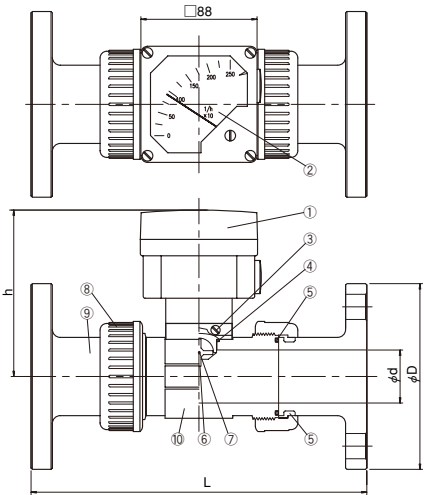

● Thread Type

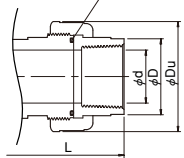

● TS Socket Type

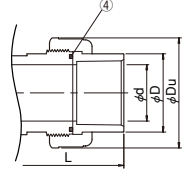

■ Parts List

No.	Part Name	Q'ty	Material
①	Transmitter	1	PC
②	Window	1	PC
③	Screw	1	SUS304
④	O-ring	1	EPDM or FPM
⑤	Set Ring	2	PVDF
⑥	Paddle	1	PVDF
⑦	Axis and bearing	1	Seramic
⑧	Union Nut	2	PVC,PP or PVDF
⑨	Socket	2	PVC,PP or PVDF
⑩	Body	1	PVC,PP or PVDF

Unit:mm

Size		φd		L		φD		h	φDu	Weight (kg/pc)		
A	B	Flange	Thread+ TS Socket	Flange	Thread+ TS Socket	Flange	Thread+ TS Socket			Flange	Thread	TS Socket
15	1/2	15	15	192	141	95	28	120	43	0.9	0.6	0.6
20	3/4	20	21	202	160	100	36	117	53	1.0	0.7	0.7
25	1	26	26	228	178	125	42	118	60	1.2	0.8	0.8
32	1 1/4	32	33	228	180	135	53	121	74	1.5	0.9	0.9
40	1 1/2	40	40	254	196	140	59	126	83	1.7	1.1	1.0
50	2	50	50	271	214	155	74	132	103	2.4	1.5	1.4

■ Specification

Measuring range	0.3~10m/s(0.5~10m/s for separated type) 15A: approx. 3~ 100 ℓ/min 20A: approx. 5~ 190 ℓ/min 25A: approx. 8~ 300 ℓ/min 32A: approx. 12~ 420 ℓ/min 40A: approx. 19~ 720 ℓ/min 50A: approx. 32~1180 ℓ/min
Accuracy	±10%RD ^{※1} (0.8~ 2m/S) ± 4%RD ^{※1} (2 ~10m/S)
Repeatability	±1%RD ^{※1}
Ambient temperature	0~60°C
Operating voltage	Mounted type : size C battery X 2pcs Separated type : DC12~30V
Current consumption	Panel type : 20mA
Protection class	IP65

Under reference conditions i.e. measuring fluid=water, ambient and water temperature=20°C, applying the minimum inlet and outlet pipe straights, matched inside pipe dimensions.
※1.RD:Reading of indication value.

■ Max. Operating Temperature & Max. Operating Pressure

Material	Max. (°C)	Max. (MPa) at room temp.
PVC	50	1.0
PP	80	
PVDF	100	

■ Flow scale

0~ 600 L/h	0~ 16m³/h
0~ 1000 L/h	0~ 25m³/h
0~ 1600 L/h	0~ 40m³/h
0~ 2500 L/h	0~ 60m³/h
0~ 4000 L/h	0~100%
0~ 6000 L/h	
0~10000 L/h	

ESLON FLOW SENSOR TYPE 8031 (Pulsed Output)



- Small ECTFE paddle type digital flow meter
 - Excellent chemical resistance
- Suitable for small flow rate of chemical piping

Parts List

No.	Part Name	Q'ty	Material
①	Housing	1	ECTFE
②	Screw	4	SUS304
③	Base Plate	1	PVC
④	Remote Control Body Cover	1	PC
⑤	Cover Thread	4	SUS316
⑥	Connector Cable	1	UP
⑦	Cable Clip	1	PA
⑧	Terminal block	1	PA
⑨	Base	1	FR6
⑩	Screw	4	SS,Ni Plated
⑪	Lock Washer	4	SUP
⑫	Spacer	2	PPS
⑬	Gasket	1	NBR

● Sensor element

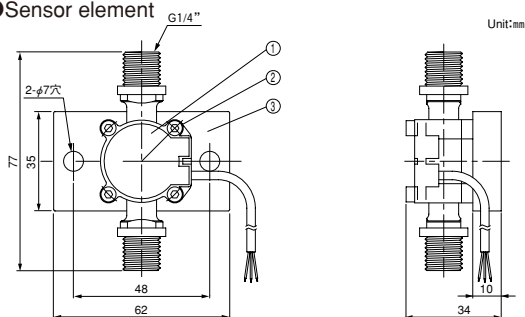

● Panel type remote controller

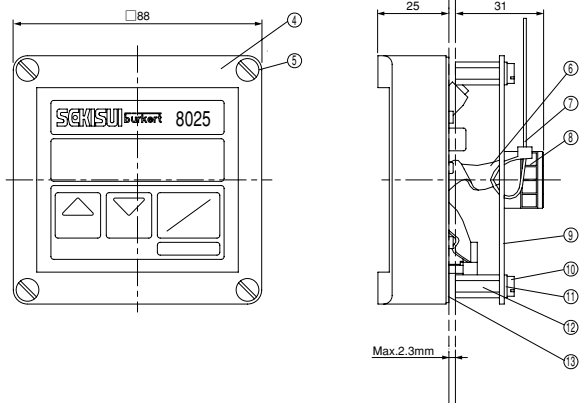

● Sensor element material

Part Name	Q'ty	Material
Paddle-wheel	1	ECTFE
Axis	1	Sapphire
Gasket	1	FPM or EPDM

● Max. Operating Temperature & Max. Operating Pressure

Material	Max. (°C)	Max. (MPa) at room temp.
ECTFE	55	0.5

● Specification

Measuring range	10~150 ℓ/h 20~600 ℓ/h
Accuracy	±2%RD ^{※1}
Repeatability	1%以下
Ambient temperature	-10~50°C
storage temp.	-10~70°C
Viscosity	1~10cSt
Output signal	Open-collector NPN
Pulse signal	
Frequency	0~300Hz
Operating voltage	DC12~24V
Current consumption	15mA at 24V
Protection class	IP65

Under reference conditions i.e. measuring fluid=water, ambient and water temperature=20°C, applying the minimum inlet and outlet pipe straights, matched inside pipe dimensions.

※1.RD=Reading of indication value

● Function table

Type	Sensor element	Display		4-20 mA	Pulse	Calibrated pulse	Relay output	Batch function	Remarks
		Moment	Integrating						
Type8031	Standard	●	●	●	●	●			
	with Relay output	●	●	●	●	●	●		
Panel type	Batch controller	※1	●					●	200~600 ℓ/h only
	Standard	●	●	●		●			
	with Relay output	●	●	●		●	●		
BOX型	Standard	●	●	●		●			
	Batch controller	※1	●					●	200~600 ℓ/h only

※1. It is displayed for two seconds by the switching operation of the display.

ESLON FLOW SENSOR TYPE 8045 (Electrode Type)



◎ Suitable for slurry or emulsified medium with electrode type

● Flange Type

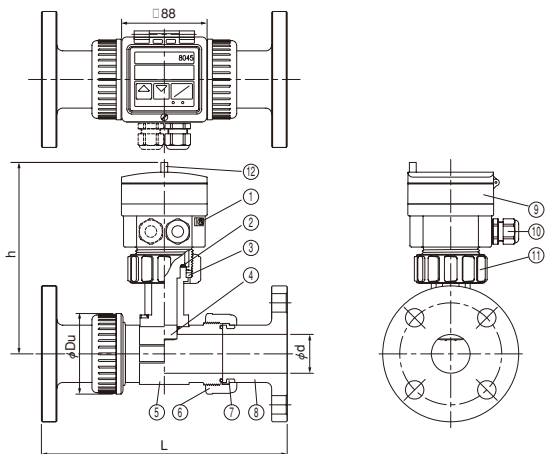

● Thread Type

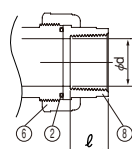

● TS Socket Type

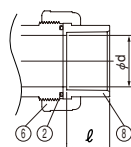

Parts List

No.	Part Name	Q'ty	Material
①	Ground screw	1	SUS304
②	O-ring	4	EPDM or FPM
③	Ring	1	PVDF
④	Electrode	1	SUS316L
⑤	Body	1	PVC,PP or PVDF
⑥	Union Nut (A)	2	PVC,PP or PVDF
⑦	Set Ring	2	PVDF
⑧	Socket	2	PVC,PP or PVDF
⑨	Transmitter	1	PC
⑩	Cable gland ^{※1}	1or2	PA
⑪	Union Nut (B)	1	PA
⑫	Cover Thread	1	SUS303

※1.Cable gland : Standard type=1pc (see solid line)
Standard with output type=2pcs (see dot-line)

Max. Operating Temperature & Max. Operating Pressure

Material	Max. (°C)	Max. (MPa) at room temp.
PVC	50	0.6
PP	80	
PVDF	100	

Unit:mm

Size		φd		L		h	Weight (kg/pc)		
A	B	Flange	Thread+TS Socket	Flange	Thread+TS Socket		Flange	Thread	TS Socket
15	1/2	15	15	192	141	173	1.0	0.8	0.8
20	3/4	20	21	202	160	171	1.1	0.8	0.8
25	1	26	26	228	178	171	1.4	0.9	0.9
32	1 1/4	32	33	228	180	174	1.6	1.1	1.1
40	1 1/2	40	40	254	196	179	1.8	1.2	1.2
50	2	50	50	271	214	185	2.5	1.6	1.5

Specification

Measuring range	0.1~10m/s 15A:approx. 1~ 100 l/min 32A:approx. 5~ 420 l/min 20A:approx. 2~ 190 l/min 40A:approx. 8~ 720 l/min 25A:approx. 3~ 300 l/min 50A:approx.12~1180 l/min
Accuracy	Teach-In:±2%RD ^{※1} Standard K-factor:±4%RD ^{※1}
Repeatability	0.25%RD ^{※1}
Linearity	± (1%RD ^{※1} + 0.1%FS ^{※2})
Conductivity	above 20μS/cm
Output signal	Calibrated pulse output Open-collector NPN/PNP,DC36V,100mAmax
	4-20mA output Load 30V:1300Ω 24V:1000Ω 18V: 700Ω
	Relay output AC250V/3A,DC30V/3A
Operating voltage	DC18~36V
Current consumption	Max. 300mA
Protection class	IP65
Ambient temperature	-10~60°C
Relative humidity	< 80% (non condensing)

Under reference conditions i.e. measuring fluid=water, ambient and water temperature=20°C, applying the minimum inlet and outlet pipe straights, matched inside pipe dimensions.
※1.RD=Reading of indication value
※2.FS=Full scale (10m/s)

Performance table

Model	Display		4-20 mA	Calibrated pulse	Relay output
	Moment	Integrating			
Standard	●	●	●	●	●
with Relay output	●	●	●	●	●

ESLON pH SENSOR TYPE 8025



Valve Type

- Available continuous measurement with multiple glass electrode type ph sensor
- Available 2 types of valve type and mounting type with long electrode for tank
- Auto pH corrective function in proportion to temperature

● Flange Type

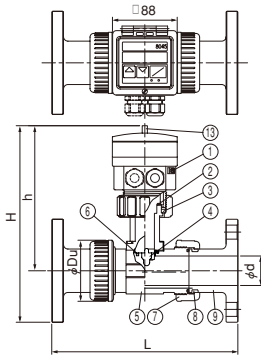

● Thread Type

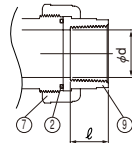

● Mounting Type for Tank

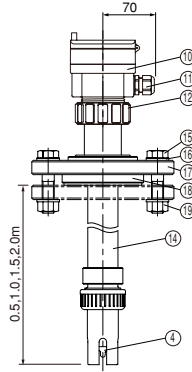

● TS Socket Type

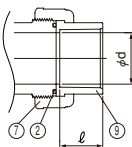

■ Parts List

No.	Part Name	Q'ty	Material
①	Ground screw	1	SUS304
②	O-ring	4	EPDM or FPM
③	Ring	1	PVDF
④	Electrode	1	Composite electrode glass sensor
⑤	Body	1	PVC,PP or PVDF
⑥	Thermo Sensor	1	Pt1000 (SUS316Ti)
⑦	Union Nut (A)	2	PVC,PP or PVDF
⑧	Set Ring	2	PVDF
⑨	Socket	2	PVC,PP or PVDF
⑩	Transmitter	1	PC
⑪	Cable gland	1or2	PA
⑫	Union Nut (B)	1	PA
⑬	Cove Thread	1	SUS303
⑭	Mounting flange for Tank	1	PP
⑮	Bolt	4	SUS304
⑯	Washer	8	SUS304
⑰	Mounting flange (A)	1	Steel inserted PP
⑱	Mounting flange (B)	1	PP
⑲	Nut	4	SUS304

Unit:mm

Size		φd		L			h	Weight (kg/pc)		
A	B	Flange	Thread+ TS Socket	Flange	Thread+ TS Socket	Flange		Thread	TS Socket	
15	1/2	15	15	192	141	173	1.0	0.8	0.8	
20	3/4	20	21	202	160	171	1.1	0.8	0.8	
25	1	26	26	228	178	171	1.4	0.9	0.9	
32	1 1/4	32	33	228	180	174	1.6	1.1	1.1	
40	1 1/2	40	40	254	196	179	1.8	1.2	1.2	
50	2	50	50	271	214	185	2.5	1.6	1.5	

■ Specification

Measuring range	0~14pH
Measuring error	±0.2%
Electrode material	Housing : glass Diaphragm : Ceramic Reference electrolyte : gel
Ambient temperature	0~60°C
storage temp.	0~60°C
Relative humidity	< 80%
Protection class	IP65
Operating voltage	DC12~30V
Current consumption	20mA 80mA (with Relay output)
Output signal	4-20mA output
	Relay output

■ Max. Operating Temperature & Max. Operating Pressure

Material	Max. (°C)	Max. (MPa) at room temp.
PVC	50	0.6
PP	80	
PVDF	100	

■ Function table

Model	Display	4-20mA	Relay output
Standard	●	●	
with Relay output	●	●	●

ORP SENSOR TYPE 8206



Valve Type

- Available continuous measurement with multiple glass electrode type ORP sensor
- Available 2 types of valve type and mounting type with long electrode for tank

Parts List

No.	Part Name	Q'ty	Material
①	Ground screw	1	SUS304
②	O-ring	4	EPDM or FPM
③	Ring	1	PVDF
④	Electrode	1	Composite electrode glass sensor
⑤	Body	1	PVC, PP or PVDF
⑥	Union Nut (A)	2	PVC, PP or PVDF
⑦	Set Ring	2	PVDF
⑧	Socket	2	PVC, PP or PVDF
⑨	Transmitter	1	PC
⑩	Cable gland	1or2	PA
⑪	Union Nut (B)	1	PA
⑫	Cover Thread	1	SUS303
⑬	Mounting flange for Tank	1	PP
⑭	Bolt	4	SUS304
⑮	Washer	8	SUS304
⑯	Mounting flange (A)	1	Steel inserted PP
⑰	Mounting flange (B)	1	PP
⑱	Nut	4	SUS304

● Flange Type

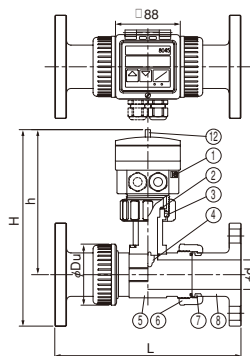

● Thread Type

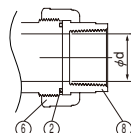

● Mounting type for Tank

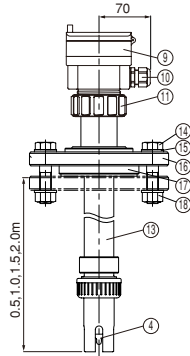

● TS Socket Type

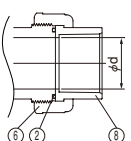

Unit:mm

Size		φd		L		h	Weight (kg/pc)		
A	B	Flange	Thread+ TS Socket	Flange	Thread+ TS Socket		Flange	Thread	TS Socket
15	1/2	15	15	192	141	173	1.0	0.8	0.8
20	3/4	20	21	202	160	171	1.1	0.8	0.8
25	1	26	26	228	178	171	1.4	0.9	0.9
32	1 1/4	32	33	228	180	174	1.6	1.1	1.1
40	1 1/2	40	40	254	196	179	1.8	1.2	1.2
50	2	50	50	271	214	185	2.5	1.6	1.5

Specification

Measuring range	-1575~+1575mV	
Measuring error	±3mV	
Electrode material	Housing : glass Diaphragm : Zirkon dioxide Reference electrolyte : gel	
Ambient temperature	0~60°C	
storage temp.	0~60°C	
Relative humidity	< 80%	
Protection class	IP65	
Operating voltage	DC12~30V	
Current consumption	20mA, 80mA (with Relay output)	
Output signal	DC4-20mA	
	4-20mA output	Load 700Ω (30V) 400Ω (24V) 100Ω (15V)
	Relay output	230V/3A X 2contact

Max. Operating Temperature & Max. Operating Pressure

Material	Max. (°C)	Max. (MPa) at room temp.
PVC	50	0.6
PP	80	
PVDF	100	

Function table

Model	Display	4-20mA	Relay output
Standard	●	●	
with Relay output	●	●	●

ESLON CONDUCTIVITY SENSOR TYPE 8225



- Available continuous measurement with graphite or stainless steel electrode type conductivity sensor
- Available 2 types of valve type and mounting type with long electrode for tank
- Auto conductivity corrective function in proportion to temperature

Flange Type

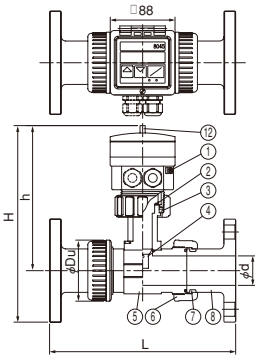

Thread Type

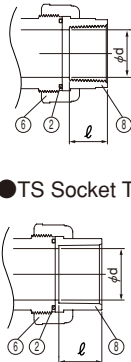

Mounting type for Tank

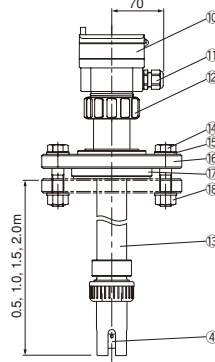

TS Socket Type

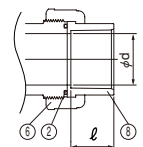

Unit:mm

Size		φd		L		h	Weight (kg/pc)		
A	B	Flange	Thread· TS Socket	Flange	Thread· TS Socket		Flange	Thread	TS Socket
32	1 1/4	32	33	228	180	174	1.6	1.1	1.1
40	1 1/2	40	40	254	196	179	1.8	1.2	1.2
50	2	50	50	271	214	185	2.5	1.6	1.5

Parts List

No.	Part Name	Q'ty	Material
①	Ground screw	1	SUS304
②	O-ring	4	EPDM or FPM
③	Ring	1	PVDF
④	Electrode	1	Graphite (K=1.0/10) SUS316Ti (K=0.1/0.01)
⑤	Body	1	PVC,PP or PVDF
⑥	Union Nut (A)	2	PVC,PP or PVDF
⑦	Set Ring	2	PVDF
⑧	Socket	2	PVC,PP or PVDF
⑨	Transmitter	1	PC
⑩	Cable gland	1or2	PA
⑪	Union Nut (B)	1	PA
⑫	Cover Thread	1	SUS303
⑬	Mounting flange for Tank	1	PP
⑭	Bolt	4	SUS304
⑮	Washer	8	SUS304
⑯	Mounting flange (A)	1	Steel inserted PP
⑰	Mounting flange (B)	1	PP
⑱	Bolt	4	SUS304

Specification

Measuring range	0.05 μ S/cm~20 μ S/cm (K=0.01) 0.5 μ S/cm~200 μ S/cm (K=0.1) 5 μ S/cm~10mS/cm (K=1.0) 500 μ S/cm~200mS/cm (K=10)
Measuring error	±5%
Electrode material	Graphite (K=1.0/10) SUS316Ti (K=0.1/0.01)
Ambient temperature	0~60°C
storage temp.	0~60°C
Relative humidity	< 80%
Protection class	IP65
Operating voltage	DC12~30V
Current consumption	20mA 80mA (with Relay output)
Output signal	DC4-20mA Load 700Ω (30V) 400Ω (24V) 100Ω (15V)
	Relay output

Max. Operating Temperature & Max. Operating Pressure

Material	Max. (°C)	Max. (MPa) at room temp.
PVC	50	0.6
PP	80	
PVDF	100	

Function table

Model	Display	4-20mA	Relay output
Standard	●	●	
with Relay output	●	●	●

Electrode Types

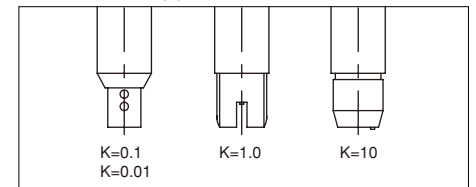

ESLON ULTRASONIC LEVEL SENSOR TYPE 8175



- Available continuous level measurement with ultrasonic reflection sensor.
- Suitable under atmosphere pollution.
- Available particular calculation function of obstructon elimination and tank capacity.
- Please be careful of the following precaution due to the property of the ultrasonic.
 - Be careful in case of using to the small liquid area of the tank due to the beam-angle of the ultrasonic. A problem may be avoided by using the pipe guide of $\phi 50$ -100.
 - Be careful in case of using to the application which occurs bubble or wave on the liquid-surface, because the ultrasonic reflect irregularly. A problem may be avoided by using the pipe guide of $\phi 50$ -100 or the wave defence by the partition.

● Monolith model

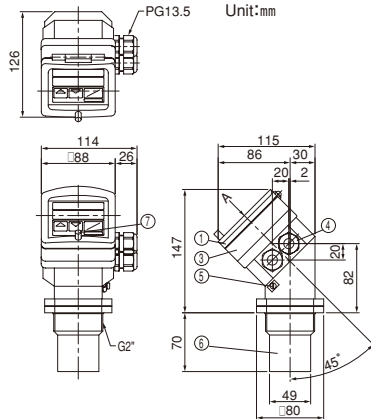

● Separate model

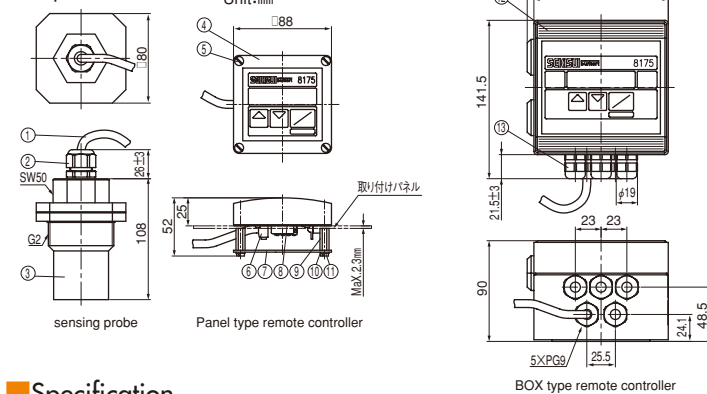

■ Parts List (Monolith model)

No.	Part Name	Q'ty	Material
①	Transmitter cover	1	PC
②	Cover Gasket	1	NBR
③	Transmitter	1	PC
④	Cable gland	2	PA
⑤	Ground screw	1	SUS304
⑥	Ultrasonic Level Sensor	1	PVDF
⑦	Cover Thread	1	SUS303

■ Parts List (Separate model)

No.	Part Name	Q'ty	Material
①	Sensor Cable	1	—
②	Cable gland (1)	1	PA
③	Ultrasonic Level Sensor	1	PVDF
④	Remote Controller Body Cover	1	PC
⑤	Cover Thread	4	SUS316
⑥	Terminal block	1	PA
⑦	Circuit board	1	FR6
⑧	Gasket	1	NBR
⑨	Spacer	2	PPS
⑩	Lock Washer	4	SUP
⑪	Screw	4	Ni plated Steel
⑫	Remote Controller Body	1	PC
⑬	Cable gland (2)	5	PA

■ Specification

Measuring range	Monolith model:0.3~10m Separate model:0.3~7m ※No bubble on the liquid surface, atmospheric pressure, ambient and liquid temperature=20°C
Resolution	±3mm
Accuracy	±0.25%FS ^{※1} ±0.15%FS ^{※1} with calibration in Teach-in mode
Full beam width	8° conical
Frequency	50kHz
Pulse rate	8 pulse/sec
Ambient temperature	-20~60°C
Pressure	0.2MPa at 25°C
Operating voltage	DC18~32V
Current consumption	Max. 200mA
Output signal	DC4~20mA (22mA at the abnormality) Load 1300Ω (32V) 1000Ω (24V) 550Ω (18V)
Relay output	2relays/3A with Relay output only
Protecting class	IP65
Cable length	10m or 20m ※Separate model only

※1: FS=Fullscale (Monolith model:10m, Separate model:7m)

■ Function table

Model	Display	4-20mA	Relay output
Standard	●	●	
with Relay output	●	●	●

Notes of Sensor

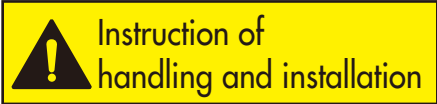

General notes (Ultrasonic Level Sensor is excluded)

- Sensor should be used at the piping of the always full water condition.
Measurement impossibility and measurement error accrue when piping is not the full water condition.

Installation example

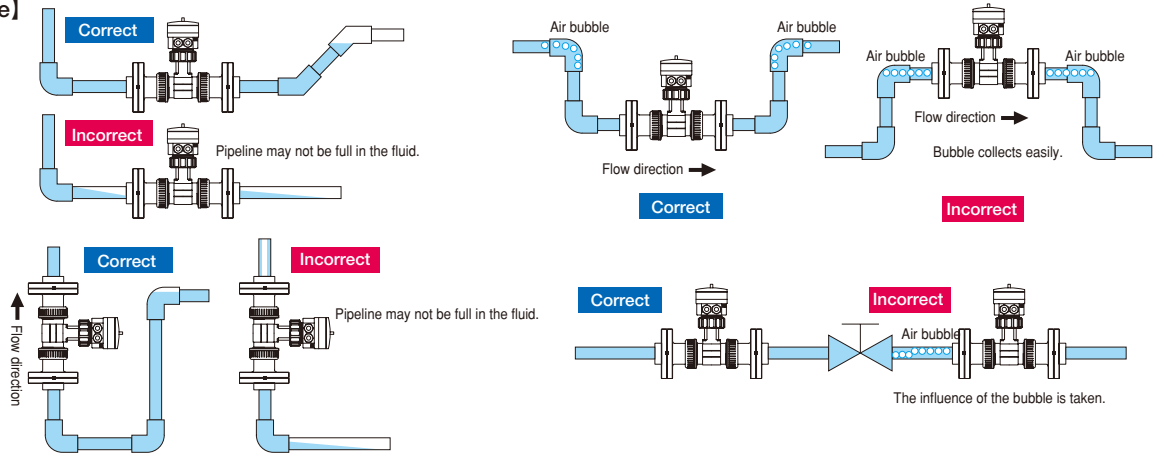

- Don't install a sensor near the machine such as pump, motor, transformer. The developmental noise causes sensor breakdown or measurement impossibility. Don't install the sensor wiring and the machine wiring in the same routing line.
- Install a blind or a cover in order to protect a sensor in case of the place to take the influence of the sunlight and the rain.

Specific instruction for each sensor

《 Digital Flow Meter 》

- Don't use it in the fiber mixed fluid because a fiber catch to Paddle.
The caught fiber to Paddle has a bad influence to the rotation, and causes a measurement error and measurement impossibility.

《 Electromagnetic Flow Meter 》

- Use it in the fluid beyond conductivity $20 \mu S/cm$.
- Don't install a sensor in the unstable conductivity fluid such as chemical injecting on the upper flow, because causes a measurement error.

《 Electromagnetic Flow Meter, PH Sensor, ORP Sensor, Conductivity Sensor 》

- Cleaning by the periodic maintenance and a dirt prevention measure are necessary because measuring impossibility is caused by the dirt of the electrode.

《 Conductivity Sensor 》

- Confirm a measurement range and choose a suitable sensor due to a measurement range of every electrode is different.

《 Ultrasonic Level Sensor 》

- Install a sensor to the bypass pipe($\phi 50 - 100$) or Install a weir, in cases where a wave or a bubble occur on the liquid level by the stirring machine, the liquid supply, and so on. It can't be used in case where a bubble occurs due to the chemical reaction.

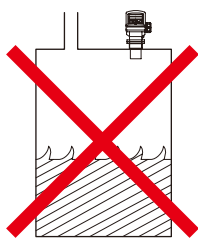

Fig.-1

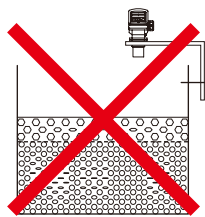

Fig.-2

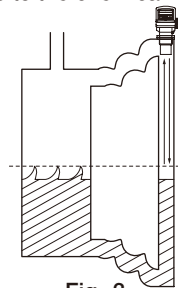
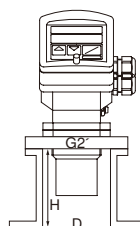

Fig.-3

- It can't be used at the gas-atmosphere such as CO_2 or NH_3 which absorbs ultrasonic.
- It can't be used because mutual interference occurs when more than one sensor is installed in one tank.
- The following dimension is necessary in case of the install to the shaft.

in case of $D=65mm, H \leq 100mm$
 in case of $D=80mm, \leq 250mm$
 in case of $D=100mm, H \leq 400mm$



- Install a shade or a cover to protect a sensor in case of the use in the place to take direct sunlight or a rainy influence.
- The adhesion of the extraneous to the sensor part causes measurement impossibility. Remove extraneous matter regularly, Or take measures.

V Technical Information

■ Technical Information ■

- Characteristic of Material ----- V-1
- Basic Physical Property of Material at Temp.20°C ----- V-1
- Chemical Resistance of Material ----- V-2
- Max. Operating Pressure at Actual Operating Temperature ----- V-3

■ Flow Characteristic ■

- Flow Characteristics of Eslon Valve ----- V-3
- Cv & Kv Values ----- V-4
- Flow Diagram ----- V-4

■ Installation ■

- Installation ----- V-5

Technical Information

Characteristic of Material

	Material	Abbreviation	General Characteristic
Valve body	Polyvinyl Chloride	PVC	Resistant against most of acids,alkalis and salts of high to low concentration level.However,the material tends to be attacked by some chemicals-such as aromatic hydrocarbon,ketones,esters and chlorinated hydrocarbon.
	Hi-Impact Polyvinyl Chloride	HI-PVC	Resistance properties are nearly the same as PVC. Having high impact resistance and durability.
	Chlorinated Polyvinyl Chloride	C-PVC	Resistance propeties are nearly the same as PVC.Having a high heatresistance,this is serviceable in the temperature range higher than the former's.
	Polypropylene	PP	Not stable against strong acids such as concentrated nitric acid and chrome acid mixture,but this is resistant against other acids,alkalis and salts.Resistant against many organic solvents(specifically the solvent with active group),but tends to be attacked by chlorinecontaining solvents,aliphatic series and aromatic hydro-carbon.
	Glass Fiber Reinforced Polypropylene	GF-PP	Having higher mechanical properties for rigidity and tensile strength than polypropylene.
	Glass Fiber Reinforced Polyamide	GF-PA	Having higher mechanical properties for rigidity, tensile strength, and good wearing characteristics.
	Vinylidene Fluoride	PVDF	Highly resistant up to a high temperature range against ordinary acids & salts and organic chemicals,but broken down by fuming sulfuric acid and strong basic amines.Aiso,the use conditions with ketone,amide,ester,organic solvent ad alkali are limited.
Seal material etc	Polytetra-fluoroethylene (Trade name Teflon)	PTFE	Resistant against ordinary acid and alkali,and not dissolved nor changed by ordinary solvent medium.Attacked by melted aikali metal and in a high temperature,by fluorine and chlorine trifluoride.
	Ethylene Propylene Rubber	EPDM	Provided with an exellent ozone-resistance and chemical-resistance.Comparatively resistant against ketone and ester,but less resistant against aromatics & alphatic families,and gasoline and oil.
	Fluororubber (Trade name Viton)	FPM	Most chemical-resistant among all rubber families.Has a good resistance against strong oxidizing acid such as concentrated sulfuric acid and nitric acid;resistant against aliphatic and aromatic families and oils,but attacked by ketones,ammonia anhydride,concentrated caustic soda,etc.
	Chlorinated polyethylene	C-PE	Provided with an excellent chemical-resistance, especially against hypochlorous acid, chromic acid, and nitric acid. ozone-resistance, and oil-resistance. Used as a modifier for plastic and rubber.

Basic Physical Property of Material for valve at Temp.20°C

Property	Unite	PVC	C-PVC (HT)	PP	GF-PP	PVDF	PTFE
Density	g/cc	1.43	1.48	0.92	1.04	1.77	2.17
Water Absorption	mg/m ²	0.04~0.06	0.04~0.06	0.01		0.04	0.00
Tensile Strength at Yield	MPa	47.1~50.1	49.0~53.9	24.5~34.3	82	49.0~53.9	19.6
Tensile Strength at 90°C	MPa		24.5	14.7		24.5	
Modulus of Elasticity	MPa	2.94×10 ⁹	2.94×10 ⁹	1.18×10 ⁹	7.3×10 ⁹	1.5×10 ⁹	3.9×10 ⁹
Flexural Strength	MPa	78.5~88.3	88.3	24.5~34.3	95.1	64.7	
Poisson's Ratio	—	0.38	0.38	0.44		0.28	
Charpy Impact Strength	kJ/m ²	6.86~9.81	6.86~9.81	6.86~9.81	11.8	17.7~19.6	2.94
Heat Deflection Temperature	°C	74	110	105	145	145	
Max Operating Temperature	°C	50	90	90	90	120	260
Linear Expansion Coefficient	/°C	7×10 ⁻⁵	7×10 ⁻⁵	12×10 ⁻⁵	4.5×10 ⁻⁵	12×10 ⁻⁵	10×10 ⁻⁵
Thermal Conductivity	W/m·K	0.15	0.14	0.12		0.12	0.7
Dielectric Strength	kV/mm	40	40	26	26	70	
Volume Resistivity	Ωcm	5.3×10 ¹⁵	5.3×10 ¹⁵	4.9×10 ¹⁵		5×10 ¹⁵	1×10 ¹⁸

Chemical Resistance of Material

Please refer to "Chemical Resistance Manual for Eslon Plastics Pipe, Valves and Relative Materials" for details of Chemical.

++ Not affected - Slightly affected but serviceable
+ Negligibly affected -- Not serviceable

Chemical	Concentration (%)	Temp. (°C)	Material										
			PVC	HT	PP	GFP	PVDC	PVDF	PTFE	EPDM	FPM		
Calcium chloride CaCl ₂	Satu	20	++	++	++	++	++	++	++	++	++	++	++
		40	++	++	++	++	++	++	++	+	+		
		60	++	++	++	++	++	++	++	-	-		
		80		++	++	++	++	++	++	++	++	++	++
Sodium chloride NaCl	Satu	20	++	++	++	++	++	++	++	++	++	++	
		40	++	++	++	++	++	++	++	++	++	++	
		60	++	++	++	++	++	++	++	++	++	++	
		80		++	++	++	++	++	++	++	++	++	
Hydrochloric acid HCl	15	20	++	++	++	++	++	++	++	++	++	++	
		40	++	++	++	++	++	++	++	+	+		
		60	++	++	++	++	+	++	++	-	-		
		80		++	++	++		++	++	--	--		
Sodium hydroxide NaOH	5	20	+	+									
		40	+	-									
		60	+	-									
		80		--									
	15	20	++	++	++	++	++	++	++	++	-		
		40	++	++	++	++		++	++	++	-		
		60	++	++	++			+	++	++	--		
		80		+	+			-	++	+			
Cresol C ₆ H ₄ (CH ₃)OH	Pure	20	-	--	-	--	++	++	++	--	+		
		40			+			++	++		+		
		60						+	++		+		
		80						+	++				
Chromic acid H ₂ CrO ₄	10	20	++	++	--	--	++	++	++	--	++		
		40	++	++			++	++	++	-	+		
		60	-	-			++	++	++	--	+		
		80		--				++	++		+		
Acetic acid CH ₃ COOH	20	20	++	++	++	++	++	++	++	++	+		
		40	+	++	++	++	++	++	++	++	-		
		60	-	+	+	+		++	++	+	-		
		80		-	-	-		+	++		--		
Sodium Hypochlorite NaClO	7	20	++	++	+	+	++	++	++	+	++		
		40	+	+	-	-	++	++	++	-	+		
		60	--	--	-	-	+	+	++	-	-		
		80											

Chemical	Concentration (%)	Temp. (°C)	Material									
			PVC	HT	PP	GFP	PVDC	PVDF	PTFE	EPDM	FPM	
Nitric acid HNO ₃	10	20	++	++	++	++	++	++	++	++	++	++
		40	++	++	++	++	++	++	++	++	++	++
		60	-	++	++	++	++	++	++	+	+	
		80		+	+	+		++	++	--	--	
Ammonium hydroxide NH ₄ OH	40	20	++	++	++	++	--	++	++	++	+	
		40	++	++	++	++		++	++	++	--	
		60	++	++	++	++		++	++	++	--	
		80			++	++		++	++			
Toluene C ₆ H ₅ CH ₃		20	--	--	+	+	--	++	++	--		
		40			-	-		++	++			
		60			--	--		+	++			
		80							++			
Hydrofluoric acid HF	Dilute	20	++	++	++	--	++	++	++	++	++	
		40	++	+	+		++	++	++	++	++	
		60	-	+	+		++	++	++	++	++	
		80		-	+		++	++	++	++	++	
Benzene C ₆ H ₆	Pure	20	-	-	+	+		++	++	--	+	
		40	--	--	-	-		+	++		+	
		60						+	++		+	
		80						-	++		+	
Formaldehyde HCHO	35	20	++	++	++	++	++	++	++	++	++	
		40	++	++	++	++	++	++	++	++	++	
		60	-	+	++	++		+	++	+	+	
		80			+	++		--	++	+	-	
Methyl alcohol CH ₃ OH		20	++	++	++	++	++	++	++	++	--	
		40	+	+	++	++	++	++	++	++		
		60	+	+	++	++	++	++	++	++		
		80			+	+		++	++	+		
Hydrogen sulfide H ₂ S		20	++	++	++	++	++	++	++	++	++	
		40	++	++	++	++	++	++	++	++	++	
		60	++	++	++	++	++	++	++	++	+	
		80		+	++	+		++	++	+		
Sulfuric acid H ₂ SO ₄	10	20	++	++	++	++	++	++	++	++	++	
		40	++	++	++	++	++	++	++	++	++	
		60	++	++	++	++		++	++	++	++	
		80		++	++	++		++	++	++	++	

Technical Information

Max. Operating Pressure at Actual Operating Temperature

Max. operating pressure at actual operating temperature can be calculated according to the following equation;

$$\text{Max. operating pressure at actual operating temp.} = \text{Max. Operating Pressure at } 20^{\circ}\text{C} \times \text{Pressure coefficient at actual operating temp.}$$

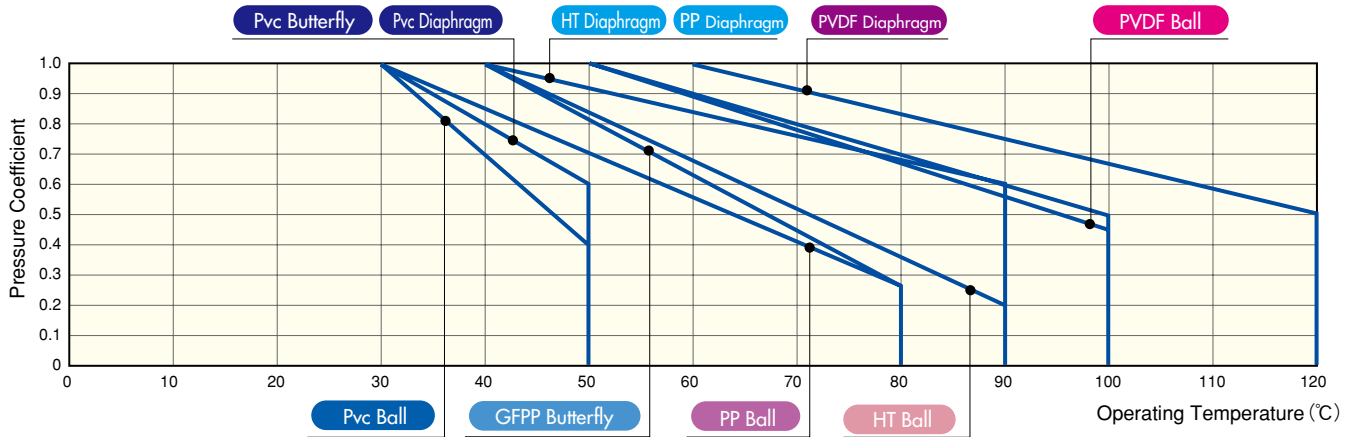

Flow Characteristics Of Eslon Valve

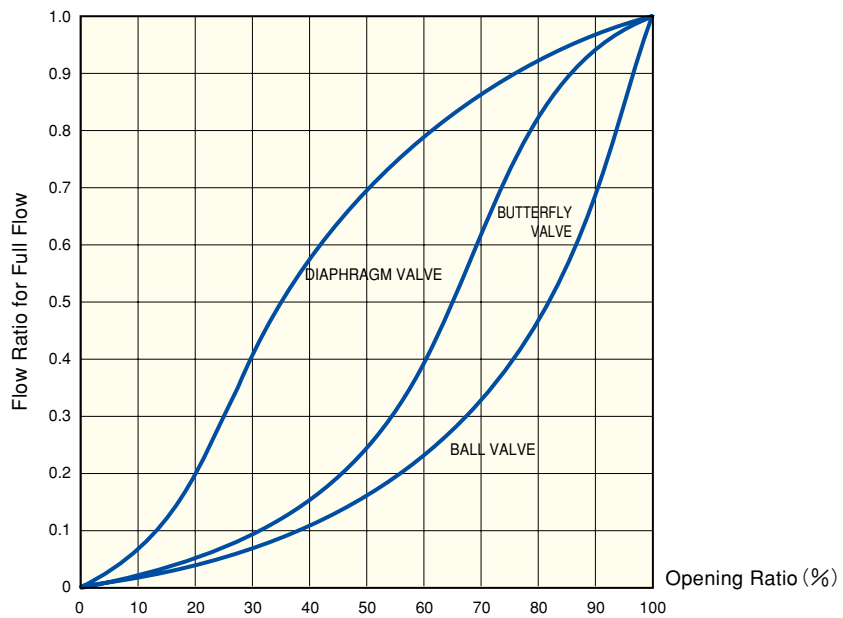

Cv & Kv Values

Cv VALUE · Kv VALUE

Size (A)		15	20	25	32	40	50	65	80	100	125	150	200	250	300	350	400	450	500	600
DIAPHRAGM VALVE	Cv	6.3	12.0	17.6	—	46.3	76.1	135	180	280	533	857	1113	1864	—	—	—	—	—	—
	Kv	89.6	171	250	—	659	1083	1920	2560	3983	7582	12191	15832	26515	—	—	—	—	—	—
BALL VALVE	Cv	12.1	31.5	48.9	80.1	154	267	352	471	780	—	—	—	—	—	—	—	—	—	—
	Kv	172	448	696	1139	2191	3798	5007	6700	11095	—	—	—	—	—	—	—	—	—	—
BUTTERFLY VALVE	Cv	—	—	—	—	74	172	282	309	446	755	993	2213	3440	4929	6311	8757	11107	14622	17945
	Kv	—	—	—	—	1053	2447	4011	4395	6344	10740	14125	31479	48993	70114	89772	124566	157994	207994	255263

Cv value (valve constant) is the flow coefficient used in USA, and non-dimensional value representing how many gallons (1 US gallon = 3.7852 litres) of water of 60°F(15.5°C) pass valve for one minute, where the pressure difference at the inlet and the outlet of the valve is 1 PSI (0.0703kgf/cm²) at its full open. 1 gallon is treated as 1Cv.

Kv value is the flow capacity coefficient used in the International Standards. It represents how many liters of water can pass the valve for one minute, where the pressure difference at the inlet and the outlet of the valve is 1 bar(1.0197kgf/cm²) at its full open.

The Cv and Kv value for liquids is expressed by the following equation;

$$Cv = Q \sqrt{\frac{\gamma}{P_1 - P_2}}$$

- Cv : Valve capacity coefficient
- Q : Volumetric flow [GALLON]
- P1 : Inlet pressure [PSI]
- P2 : Outlet pressure [PSI]
- γ : Liquid density [b/gal]

$$Cv = 0.0703Kv$$

Flow Diagram

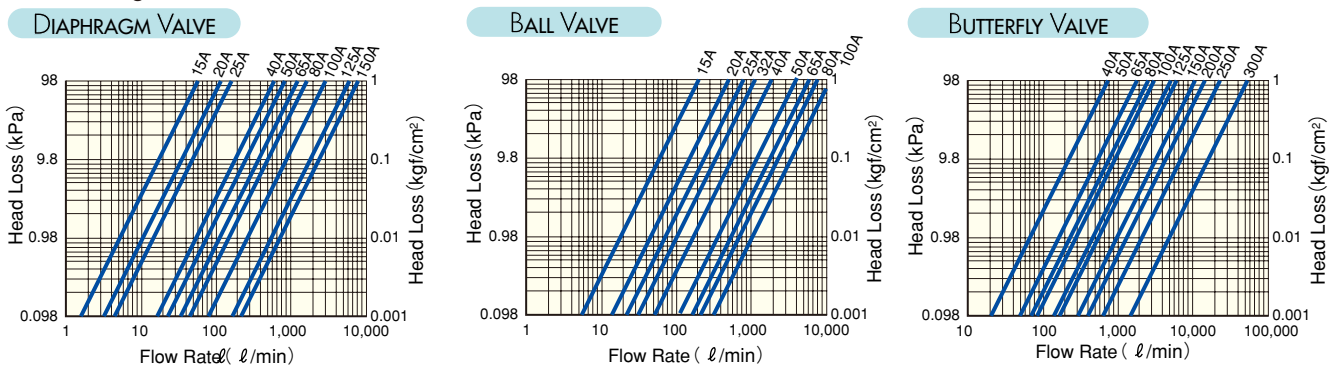

CAUTION IN USE OF ESLON AUTOMATIC VALVES

 Pay special attention on items with this mark, because it may cause personal accident if the caution in question is neglected.

1 Handling and Storage

- 1 Valves need to be handled with care and refrain from dropping and throwing. Strong impact may affect its performance of Rigid PVC product.
 - 2 A large nominal diameter pipe can be heavy, make sure for 2-man to unload and handle.
 - 3 Store un-wrapped and stack up product orderly for long time storage.
- Motor valve**
- 4 Do not use it outdoors, and not storage in the locations subject to high temperatures and high humidity.

2 Installation

- 1 Sufficient ventilation is needed for the installation under corrosive environment.
- 2 Do not install the products in place under extremely cold and humid.
- 3 Do not install the actuator downward, it should be installing upward or sideways.
- 4 After the valve was installed, Do not give the stress of the tensile, the twisting or the bending to the valve.
- 5 Confirm the coaxial of pipe-axis and valve-axis
Do not do uneven tightening, The bolt of flange should be tightened with the diagonal.
- 6 Do not give to the valve and the pipe line the excessive force or frequency, and should install proper support.
- 7 Do not tighten the union nut of the ball valve excessively.
If the union nut is excessively fastened, the actuator may not work due to over-ability of torque.

Motor valve

- 8 Not explosion-proof type, Do not install it in the flammable atmosphere.
- 9 The actuator is not waterproof type.
In case of the outdoor use, should install waterproof countermeasure such as the cover or the roof.
And should install to downward wiring or seal the cable connector by such like putty to stop water seeping from wiring line.

3 Operation

Air operated valve

- 1 Operation-air should be dry-air
- 2 If the operation-air is high pressure, should reduce to the proper pressure.

Table -1. The proper operation-air pressure of the air operated valve

Double Action Valve	0.4MPa
Single Action Valve	0.5MPa

- 3 Should test at the air-pressure of less than 0.5Mpa(Double Action Valve) and 0.6Mpa(Single Action Valve) as for the operation test or the flow test as well.
- 4 Should use a size of more than 6mm to the supply tube of operation air.
The open-close speed of the valve may take the influence of the supply amount of air by the tube size.
- 5 Do not turn the upper shaft-top of the actuator by an adjustable wrench and so on as manual operation in the pneumatic ball valve (Double&Single Action Type) and the pneumatic butterfly valve(Double&Single Action Type).
It is very dangerous due to the reaction of the spring torque or the air pressure.
Should equip optional manual-operation-unit if the manual operation is necessary.

Motor valve

- 6 Should keep the allowable voltage and the power source spec. indicated in actuator strictly.
- 7 Electrical wiring should follow the connecting diagram indicated on the side of actuator.
- 8 Should install the grounding wire as a prevention of danger surely.
- 9 The AC-source is limited to the single phase AC.
- 10 When the one with positioner was ordered, Should install a peripheral device such as a balancing relay-unit, a detect-sensor and a controller, at the same time for the proportional control of flow rate surely.
Be careful because the actuator may break down, if Action of ON-OFF continues without the proportional control.
- 11 Do not splash water to the actuator.
- 12 The opening and closing speed of the motor valve isn't changed.

Standard Supporting Method

The Diaphragm Valve

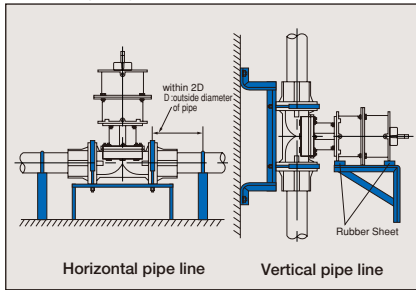

The Ball Valve

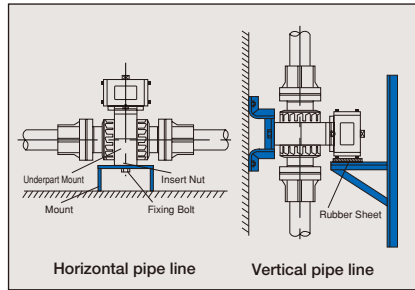

The Butterfly Valve

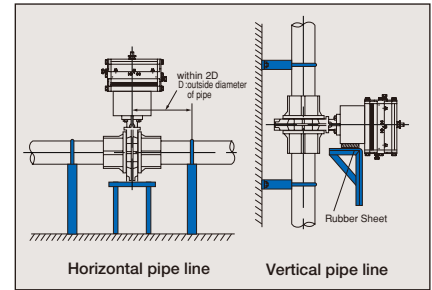

4 Control of maintenance

1 If decomposition or assembling of the valve is necessary for the maintenance, Should understand the manual fully and follow the mentioned directions.

2 Should carry out a maintenance inspection in every 3-6 months.

3 As for the details such as a construction or an use application, the others, see the manual of each model.

Air operated valve

4 After a valve is installed in the pipeline, the resolution/installation of the spring unit of the actuator is prohibited strictly. It is very dangerous, and causes a trouble.

5 Lubricating oil is un-necessity.

Motor valve

6 Do not resolve the actuator.

7 When the thermal protector worked, it return to the normality condition after a period of time.

But, Should investigate the cause that a motor overheated, prevent recurrence.

5 Connecting Flanges

1 Eslon Packing (gasket) to seal is recommended to use.

2 Bolts needed to be snugged evenly and washers, spring washers must be used with both of bolts and nuts to maintain strength of flanges.

3 There should not be seen any gap between flanges when bolts are tightened.

4 Do not connect to any metal flanged pipe (including LP pipes).

5 Tighten bolts diagonally as shown below.

6 Recommended torque for bolts can be found in Table-2 (when EPDM Eslon packing is used).

7 Proper sizes of bolts are recommended to use as shown in Table-3 for proper installation.

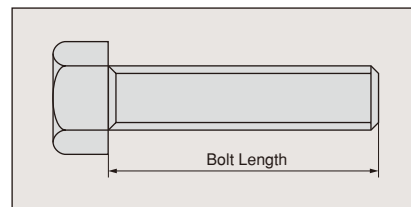
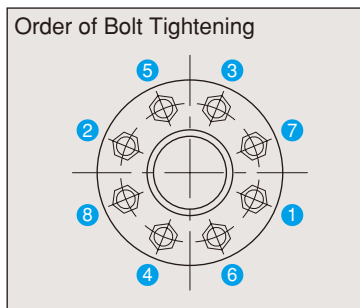

Table-2 Torque Standards for Bolt Tightening

Unit: N·m (kgf·cm)

Size (A)	15~20	25~50	65~100	125~200	250~300
Torque	15 {150}	30 {300}	45 {450}	55 {550}	65 {650}

Table-3 The bolt for the flange connection

Unit: mm

	Nominal Diameter (A)	15	20	25	32	40	50	65	75	80	100	125	150	200	250	300	350	400	450	500	600
		BALL-TS Flange *1.	Bolt Diameter	M12	M12	M16	M16	M16	M16	M16	—	M16	M16	M20	M20	M20	M22	M22	—	—	—
	Bolt Length	50	50	55	60	60	70	75	—	75	75	80	85	90	95	100	—	—	—	—	—
TS Flange *2.	Bolt Diameter	M10	M10	M10	M12	M12	M12	M12	—	M16	M16	M16	M16	M20	M22	—	—	—	—	—	—
	Bolt Length	45	45	45	50	50	55	55	—	55	60	60	65	90	95	—	—	—	—	—	—
TS Flange *3.	Bolt Diameter	—	—	—	—	—	—	—	M16	—	M16	M16	M16	M16	M20	M20	—	—	—	—	—
	Bolt Length	—	—	—	—	—	—	—	75	—	80	80	85	90	95	100	—	—	—	—	—
DIAPHRAGM *1.	Bolt Diameter	M12	M12	M16	—	M16	M16	M16	—	M16	M16	M20	M20	M20	M22	—	—	—	—	—	—
	Bolt Length	45	45	50	—	55	65	70	—	70	80	80	85	90	95	—	—	—	—	—	—
BUTTERFLY VALVE	Bolt Diameter	—	—	—	—	M16	M16	M16	—	M16	M16	M20	M20	M20	M22	M22	M22	M24	M24	M24	M30
	Bolt Length	—	—	—	—	90	110	120	—	120	130	140	140	160	180	210	250	265	280	295	330

* 1. : for the 10K-Flange of JIS-Standard

* 2. : for the 5K-Flange of JIS-Standard

* 3. : for the Flange of Water-Service

SEKISUI CHEMICAL CO.,LTD

Valves, Industrial Pipes & Materials Division 2-3-17 Toranomon Minatoku,Tokyo.105-8450 Japan
TEL +81-3-5521-0555 FAX +81-3-5521-0557

<http://www.eslon-plant.jp> E-mail: eslon_valve@sekisui.jp

SEKISUI CHEMICAL CO., LTD. Tokyo Valves, Industrial Pipes & Material Sales Office
2-3-17 Toranomon, Minato-ku, Tokyo 105-8450 Japan
TEL +81-3-5521-0620 FAX +81-3-5521-0621

SEKISUI SANIDENG CO., LTD.
No.18 ching-1st, Wuchi Town, Taichung Hsien, Taiwan
(Chung Kang Economic Processing Zone)
TEL +866-4-2657-3688 FAX +866-4-2657-3166

SEKISUI (HONG KONG) LTD.
8th Floor, 111 Leighton Road, Causeway Bay, Hong Kong
TEL +852-2890-9161 FAX +852-2577-1908

SEKISUI (SHANGHAI) INTERNATIONAL TRADING CO., LTD.
Room 702-705, Metro Tower, No.30, Tianyaoqiao Road Shanghai. 200030 P.R.China
TEL +86-21-64820638 FAX +86-21-64820639

SEKISUI CHEMICAL SINGAPORE (PTE.)LTD.
2 Jurong East Street Road 21, #05-17, IMM Building, Singapore 609601
TEL +65-562-5081 FAX +65-562-5021

Malaysia Office
163-2-13, Wisma Mah Sing, Jalan Sungei Besi, 57100 Kuala Lumpur, Malaysia
TEL +60-3-222-5233 FAX +60-3-222-7496

Thailand Office
75/22 11th Floor, Richmond Building, Sukhumvit Soi 26, Sukhumvit Road, Klongton, Kongtoey, Bangkok 10110, Thailand
TEL +66-2-2618282 FAX +66-2-2618284

KLEERDEX COMPANY, LLC.
100 Gaither Drive, Suite B, Mount Laurel, NJ 08054, U.S.A.
TEL +1-856-866-1700 FAX +1-856-866-9728

SEKISUI CHEMICAL G.m.b.H.
Cantadorstr.3 40211 Dusseldorf , Germany
TEL +49-211-369770 FAX+49-211-3697731

Printed September.2006.1st Edition
Eslon Valve
Automatic Operation
Valves & Sensors
catalogue
SEKISUI CHEMICAL CO.,LTD
Valves, Industrial Pipes & Materials Division
